



LEON CUP RACER



2014

TECHNICAL MANUAL

INDEX

1	GENERAL INFORMANTION	4
1.1	Vehicle & parts identification.....	4
1.2	Dimensions and weights	5
1.3	Fluids and tires information	6
2	TECHNICAL SPECIFICATIONS	7
2.1	Engine	7
2.2	Engine control & service	8
2.3	Fuel.....	9
2.3.1	Air filter.....	10
2.4	Gear box	11
2.5	Gearbox control & service.....	12
2.6	FDX - Slip differential control & service	12
2.7	Gear lever functions.....	13
2.7.1	Launch control porcess	14
2.7.2	Central console command.....	15
2.7.3	Steering wheel functions.....	15
2.8	Brakes	17
2.9	Dampers and Springs.....	18
3	SETTING ADJUSTMENTS	22
3.1	Tire.....	22
4	Front suspension	24
4.1	Anti roll bars	24
4.2	Kinematics	24
4.2.1	Front Camber and Toe adjustment.....	26
4.3	Rear suspension.....	28
4.3.1	Rear Caber regulation	28
4.4	Car set up table	29
4.5	Alignment	30
5	ELECTRIC.....	31
5.1	General information	31

5.2	Modules	31
5.3	Data Logger	32
5.3.1	MXG channel expansion scheme	34
5.4	Display	36
5.4.1	Driver pages:	36
5.4.2	Display alarms and shift lights	37
5.5	Transponder:	38
5.6	Extra connectors:.....	38
6	Bodywork & aero.....	39
6.1	Material of bodywork panel.....	39
6.2	Rear wing.....	40
7	SAFETY	41
8	Parts mileage	42
ANNEXE (Torques)		

1 GENERAL INFORMANTION

1.1 Vehicle & parts identification

V.I.N. (Vehicle Identification Number) is welded on the roll cage

Nº: VSSMK35F4ESSPxxxx



Engine identification number it's on a label in the distribution cover.

Nº: CJX xxxxxxxx

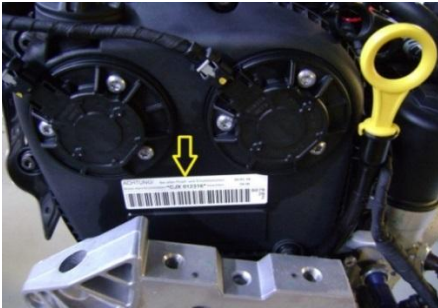

Gear box identification number it's engraved on the aluminum carcass.

Nº: COxx



Electronic slip differential identification number it's engraved on the aluminum carcass.

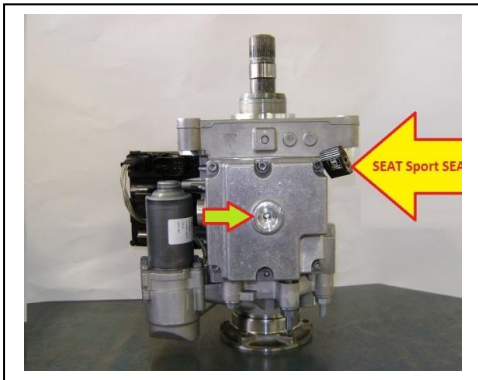

1.2 Dimensions and weights

Dimensions		
Overall length	4382 mm	
Overall bodywork front width	1950 mm	Measured on the mud-ward at the front axle
Overall bodywork rear width	1950 mm	Measured on the mud-ward at the rear axle
Wheel base	2660 mm	
Over hang front	897 mm	
Over hang rear	825 mm	
Over hang rear wing	168 mm	From the wing vertical to the bumper
Minimum body work height	1360 mm	At ride height 60mm to the ground
Minimum ground clearance	free	60 mm is the performance recommendation

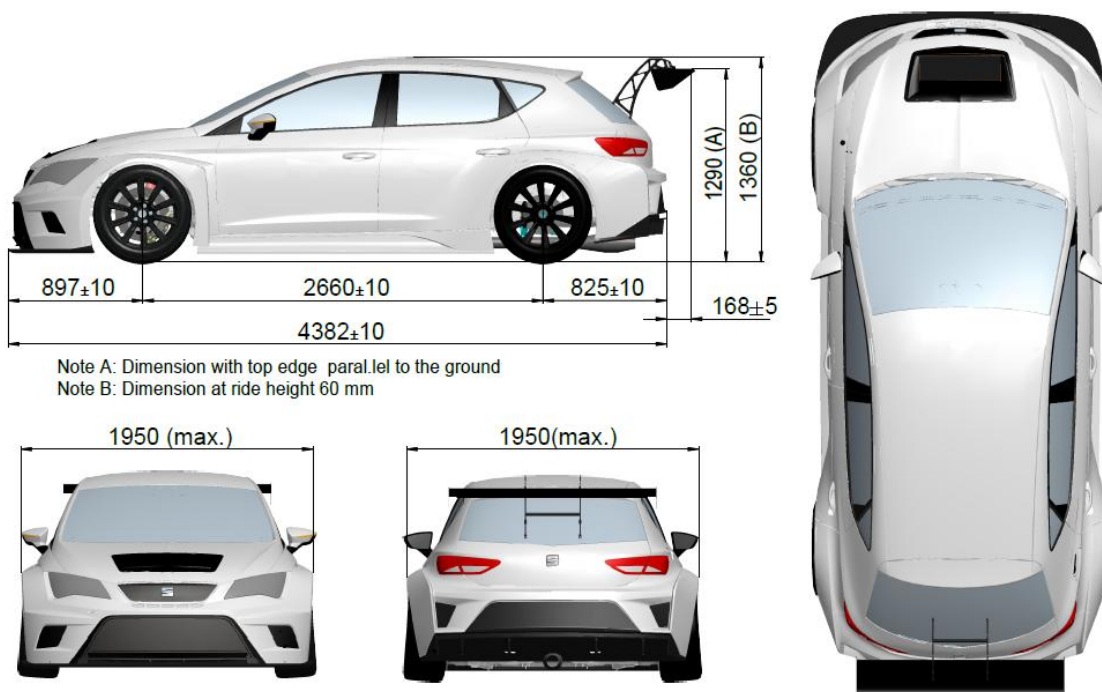



Weight:	
Total weight in race conditions without fuel	1150 Kg (1)
Car balance	63,2% front ⇄ 56,8% rear
Distribution weight/power	1,48 g/cv

Note:

(1) This value means the minimum weight on the "Technical Regulations" in race conditions.

1.3 Fluids and tires information

Fluids	From	Remarks	Quantity
Engine		CASTROL EDGE w10-60 VN0000052500	5. lts (filter) 0.5 lts
Gear box	VW-Audi	_G052182A2	Substitution 5.2 lts Mechatronica 3 – 4 lts
Electronic Slip Differential	VW	G 060 175 A2	Unit 0.7 lts Substitution 0.5 lts
Drive shaft	VW-Audi	VN0000040401	100gr
Coolant		VN0000060400	5 lts
Brake fluid		CASTROL SRF VN0000062400	–
Fuel	PANTA	NS 102 Ron	
Windscreen cleaner	Free		0.....2 lts

Notes:

- SEAT Leon Eurocup: Use only the fuel distributed on the race track. (technical & sportive regulations). **It's not permitted to use other fuel type.**
- **It's forbidden any product addition on the fuel.**
- The fuel allowed on the SEAT Eurocup championship is marked with an identifier to permit the marshals control. If for any reason (in a previous test,, etc) you were using other fuel you must replace all fuel in the fuel tank for the Eurocup one.
- **Is recommended don't mixt the fuels. The Eurocup fuel could be contaminated.**
- Gearbox and Slip diffential are supplied with the right level. **It's not necessary any level control** if there aren't leakages.

2 TECHNICAL SPECIFICATIONS

2.1 Engine

ENGINE FEATURES	
Type	2.0 TSI / Turbocharged & direct injection
Engine identification	CJX
Cylinder capacity	1984 cc
Corrected cylinder capacity	1984 x 1.7 = 3372,8
Maximum power	242 KW (330 Hp) at 6250rpm
Maximum torque (Nm/ rpm)	410 Nm at 4600 rpm
Max rpm	6800 rpm
Specific Power	165 CV/l
Electronic control unit	CONTINENTAL SIMOS 18.1
Fuel	RON MIN 98 , RON MAX 102
Fuel Consumption	0,37 to 0,42 l/km
Exhaust / dB	Racing Catalyst FIA Homologated / 100 dB
Distribution	Chain (sealed)
Oil system	Wet sump
Water pump	One electric water pump + two auxiliary pumps
Water thermostat	Double electronic thermostat
Fan range	Operating range 92°C to 87°C

Engine power and torque curves:

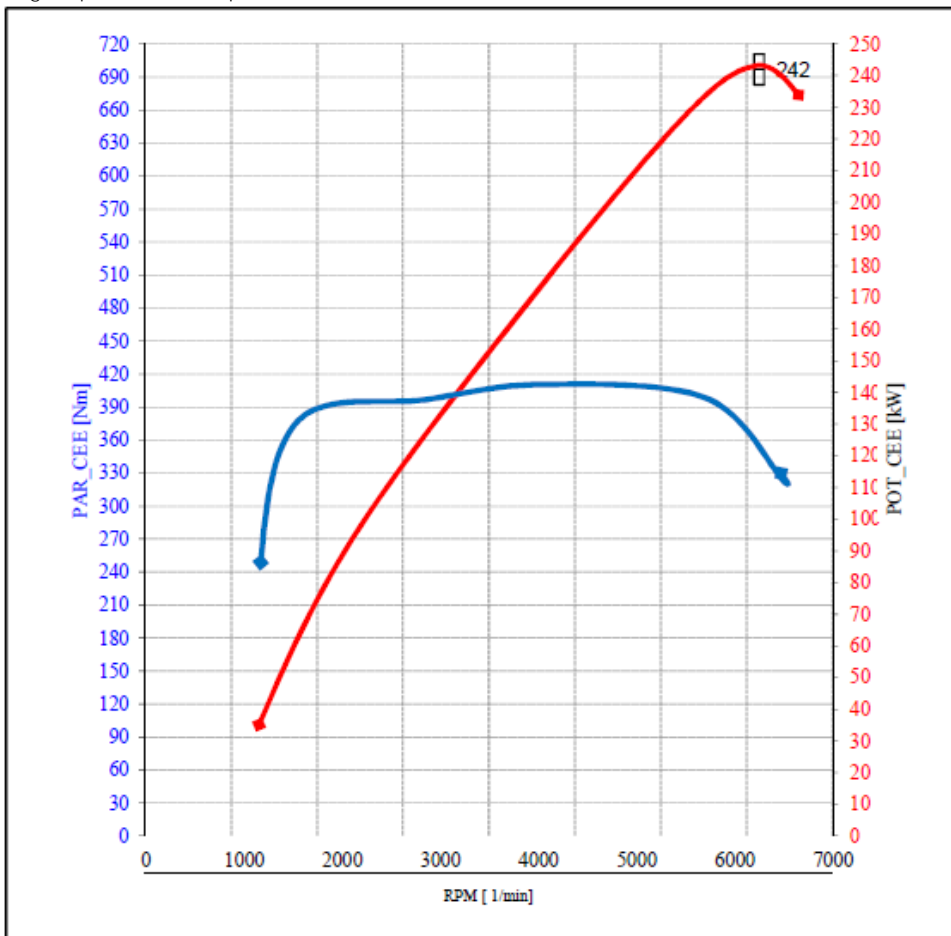

2.2 Engine control & service

Following the more frequent maintenance issues. For more detailed maintenance or parts substitution information download yourself the “mechanical notes” from our web, “www.seat-sport.com”.

Control routine before start to run:

- Check the oil level: It has to be at top of the level dipstick indication in cold conditions. It is possible to fit up to 1mm over the max level.
- Check the water level before start.
- With the engine running, check there is any oil or water or fuel leakage.
- Check the fan functionality. Operating range 92°C to 87°C.
- Don not push the engine until the water temperature its upper to 80°C.

Maintenance routine:

- Change the engine oil and oil filter in the indicated mileage.
- Use always the fluids and spare parts from VW group “original parts”, detailed on the Leon Cup Racer parts catalogue
- Clean and service the air filter each event. In urban circuits is recommended clean or replace more frequently.
- Check that the alternator belt is clean and there **aren't small stones** inside the PolIV.
- Often clean the radiator and intercooler panel.
- If any doubt, contact to the SEAT Sport service.

Distributial seal view



Turbo charger seal view

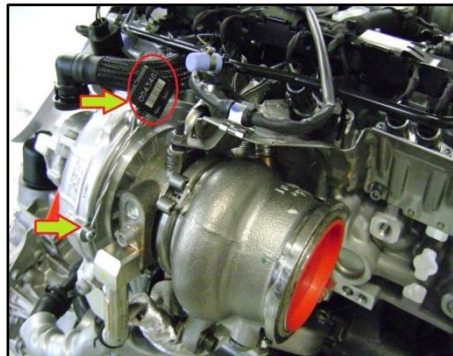

Parts subject to frequent service:

Engine	Torque	Remarks
Oil drain plug	By hand	Change the plastic cap (provided with the oil filter)
Oil filter plastic cover	50 Nm	
Oil filter	<<	Moisten the “O” rings

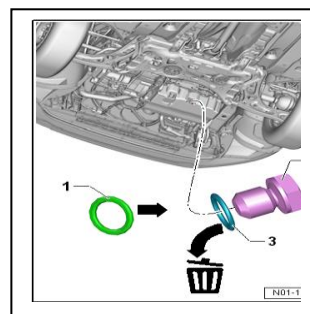
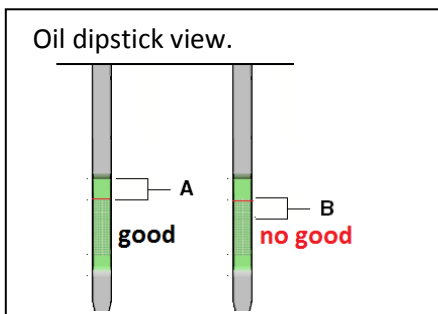

2.3 Fuel

The fuel tank is coming from series using the standard flow fuel pump and in addition a second flow pump on the opposite side.

The Leon Cup Racer body shell is ready to add an additional fuel tank. This tank is additional, connected in line and supplying the fuel to the first one.

Standard Fuel tank features	
Fuel tank type	Standard fuel tank from Quattro version
Capacity	55 lts Standard tank / *option 60 lt additional fuel tank (LR version)
Minimum fuel level before engine fault	> 5 lts.
Additional fuel tank features	
Features	FT3 FIA Homologated
Capacity	60 lt additional fuel tank // possible to reduce the capacity by adding balls.
	This additional fuel tank don't have fuel pump. It supplies the main tank by gravity.

Notes:

- The Quattro version fuel tank permits use a straight exhaust decreasing the fuel temperature for the exhaust irradiation. Check all tack protections are in good conditions.
- After a crash or out track driving check the inner flow fuel pumps fixations.

Fuel tank drain:

Hydraulic: There is a FIA fuel connector placed on the engine bay. ("a" view)

Electric: The car wiring loom is ready to connect an interface wiring to activate the tank pump. ("b" view)

The pump activation system is connected to the battery directly. For safety, is strongly recommended to carry out the process with the main switch off.

- View (a) -

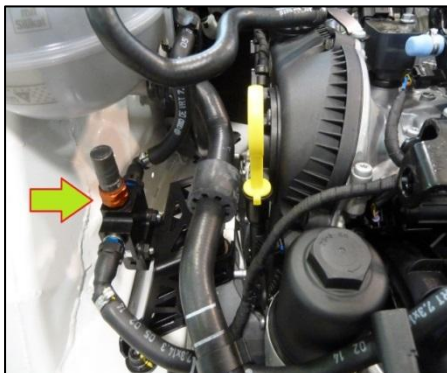

- View (b) -



Note:

- During the drain process is strongly recommended to stop the process at the end. This is for no damaged fuel pump running without fuel.
- On the Leon Cup Racer parts catalogue it is available the extraction kit.
- To carry out this procedure is recommended to connect the extraction tool to the battery help connector on the car.

2.3.1 Air filter

Air filter	Torque	Remarks
Air filter substitution	By hand	4 small bolts over plastic. Be careful.
Air filter clean		1) Clean the cotton air filter following the procedure showed. 2) DO NOT use compressed air or high-pressure air to clean. Use only the recommended oil for cotton filters.

Notes:

- **The air filter type and measures are identified on the “Technical Regulations”. It’s not allowed any modification or change.**
- The air filter clean and right oiled is mainly for the turbo charger live. Is strongly recommended follow the clean procedure as well as the timing.
- After a use in rain conditions is recommended the cleaning or change.

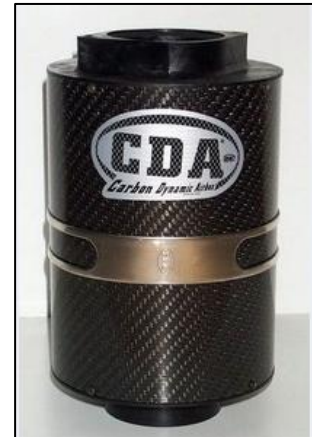

Air filter std. clean procedure



1 Remove the larger dirt by shaking or tapping your filter gently onto a clean surface. **DO NOT** use compressed air which may damage the filtering element.



2 Distribute the BMC detergent on the filter. Allow to absorb for about 10 minutes. **DO NOT** use caustic products such as petrol or oil. **USE ONLY BMC DETERGENT.**



3 Wash your filter in cold water. Rinse well ensuring that dirt does not enter the filter pleats. **DO NOT** use high-pressure water.



4 Let in a accurate proper way your filter dry naturally away from heat sources on absorbent paper or on a clean cloth. **DO NOT** use a hair-dryer or compressed air.



5 Remove the original top from the regenerating fluid bottle. Make a small hole in the spout dispenser and screw onto the bottle. For correct oiling we recommend passing the regenerating fluid twice over every pleat on both sides of the filter.



6 The oiling procedure using the aerosol spray. Hold the spray 15 cm from the filter and spray the complete surface. Repeat the operation on both sides of the filter.



7 Allow the oil to absorb on a level surface for around 30 minutes. Remove any excess oil on the rubber and check that the filtering element is homogeneously red (Picture 7). If not, repeat the oiling process described Previously. After oiling the filter is ready to be reinstalled.

2.4 Gear box

Gear box features	
Transmission	Front wheel drive
Gear box	6 speed DSG
Differential	Electronic slip differential FDX
Differential settings	3 maps / driver selection active (steering wheel module)
Clutch	Double multidisc clutch in oil bath
Gear box mode command	Electronic on the central gear lever.
Gear shift	Paddles on the steering wheel
Gbx. Electronic Control Unit	Integrated mechatronic in oil bath
Cooling system	Exchanger oil - water
Launch control system	Activated
Down shift over rev protection	Activated

Gear box Ratios									
GROUP 1-2-3-4	15	72	0,208			83	180	189	DIF Km/h
GROUP 5-6	20	72	0,278			RPM1	GEAR SHIFT	CUT	
FINAL RATIO	1	1	1,000						
GEAR	Prim Z1	Sec Z2	Rel canvi	Rel total	3000	6500	6800	DIF RPM	
1 ^a	13	38	0,342	0,071	26	56	58		
2 ^a	22	45	0,489	0,102	37	80	83	1952	
3 ^a	28	41	0,683	0,142	51	111	117	1847	
4 ^a	38	41	0,927	0,193	70	151	158	1711	
5 ^a	32	35	0,914	0,254	92	199	208	1558	
6 ^a	38	35	1,086	0,302	109	236	247	1026	

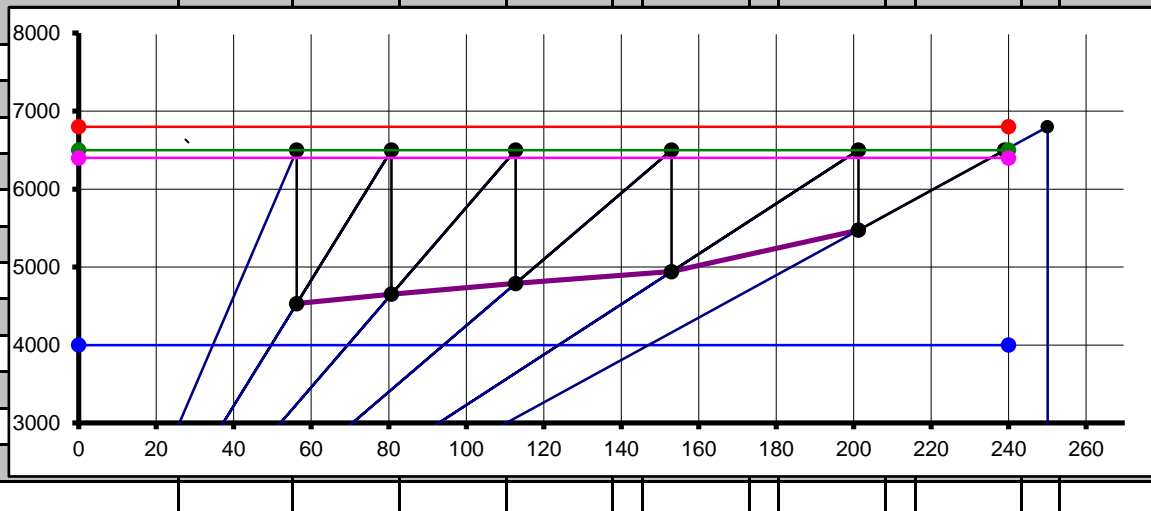

2.5 Gearbox control & service

Following the more frequent maintenance issues. For more detailed maintenance or parts substitution information download yourself the “mechanical notes” from our web, www.seat-sport.com”.

Control routine before start:

- Check that there isn't any oil leakage
- Operating range 70°C to 135°C.
- Do not load the engine until the gear box temperature its upper to 70°C. (control on the display screen).
- Check the SEAT Sport seal is in good condition.

Note:

The SEAT Sport seal forms part of the “Technical Regulations”.

Routine maintenance:

- Change the gear box oil and filter in the indicated mileage. (see mileage table)
- Oil filter, as well as the rest of the engine spare parts must be VW group original parts, detailed on the Leon Cup Racer parts catalogue.
- **If there isn't any oil leakage there is not necessary any level control.**
- For more detailed maintenance or parts substitution information download yourself the “mechanical notes” from our web, www.seat-sport.com”.

Mechatronica (green narrow)

a) Gear box –mechatronica view-

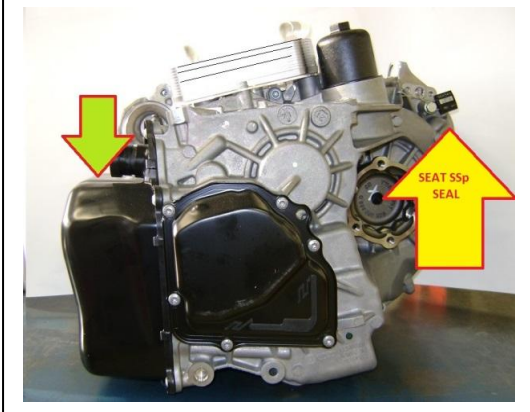

b) Gear box –gear box seal view-

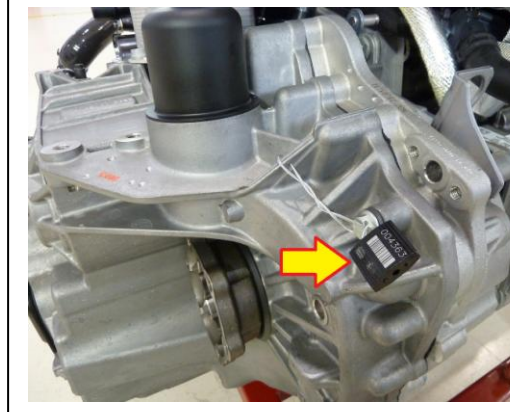

2.6 FDX - Slip differential control & service

Routine maintenance:

- Change the FDX oil in the indicated mileage. (See mileage table). Use only the recommended oil.
- **If there isn't any oil leakage there is not necessary any level control.**
- Send to SEAT Sport for revision when recommended mileage is reached.

Slip differential jobs	Torque	Remarks
FDX oil level check cap	15 Nm	Change every time

a) FDX view – level cap and seal)

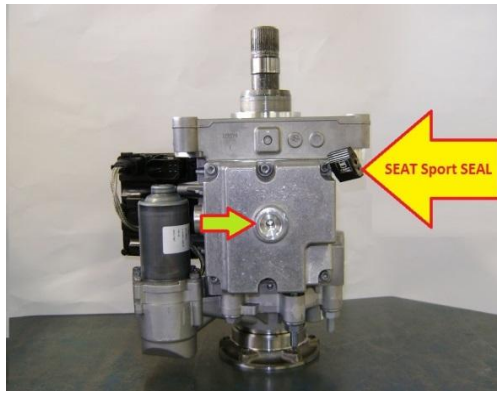

c) FDX level cap – bottom view-

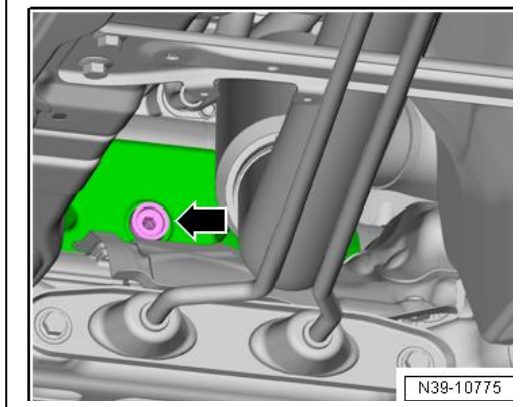

Note:

- In case of disassemble the unit from the car, the unit must be positioned in vertical position, as is shown in the picture, to avoid any oil leakage.

2.7 Gear lever functions

The gear lever, placed on the center tunnel, enables to activate different command modes. The features for each command mode are:

Gear lever position	Mode	Remarks
P	Parking mode	Use to block the car Safety for team staff when car is stopped
R	Reverse	(not allowed on the pits zone)
N	Neutral	No gear engaged
D/S	Automatic mode	D= no racing mode S= Racing mode / high engine speed shifting / racing down shift.
Tip +/-	Manual shifting “race mode”	Shifting through the gear lever +/- mode or using steering wheel paddles

“P” parking mode:

Parking mode is a lever position that fixes the transmission through a mechanical cable. Use only this position when you want to block the car.

- It's only possible to put lock or remove the parking mode if the car is completely stopped and the brake pedal is pressed.
- Never try to put the gear lever in “P” if the car is not completely stopped. If this happens the gear box might be seriously damaged.
- If for any reason the brake signal is not available and gear lever blocked in “P” position, the grey button, sign (P)”, on the steering wheel module permit to unlock the gear lever command.

“R” reverse mode:

- It's only possible to put on and take out the “R” (reverse) mode if the car is completely stopped and the brake pedal is pressed.

“N” neutral mode:

- In “N” mode it is possible to move the car to park, etc., pushing externally. (pit lane use)

“D” automatic mode:

- Not advisable for race. “D” mode is only advisable to move the car on the paddock zone. The gear shifting in a low range.

“S” automatic mode:

- From “D” position is necessary to do a “tip” rearward on the gear lever to insert the “S” mode. The gear mode symbol is showed on the display screen.
- Not recommended for race.
- Aggressive in upshifting and down shifting.
- It’s possible to use “S” mode in the “launch control process”. The gear will shift up automatically and driver can pass to Tip mode in any moment.
- Driving in “D” or “S” mode is not advisable to use the paddles.
- It’s possible to pass from “D” or “S” to Tip and backwards always and in any moment.



2.7.1 Launch control process

Launch control system permit reach a given level of engine speed with the clutch activate and gear inserted. This system it’s activating when wheels are absolutely stopped and brake pedal is pressed.

Process:

1. Car have to be stopped
2. Brake pedal pushed. (Brake press >10 bar)
3. Gear lever in “S” or “Tip” mode (gear lever on the right side)
 - Accelerate the engine at the choice level. It is advisable between 3600 to 4500 rpm. Engine speed limit is at 4500 rpm.
4. Release the brake pedal and car will go ahead.
Control with the gas pedal the wheel spin and the engine don’t arrive at the wheel spin.

Notes:

- Using the “S” mode, up shift is automatic.
- Using the “Tip” mode driver has to pay attention because engine speed limit arrives earlier and gear will not shift up automatically. (engine limiter active)
- There is a delay between the brake pedal off and car launch. Driver has to be in account.
- Down to 3200 rpm the system doesn’t work sufficiently strong

2.7.2 Central console command

There are four commands on the center console:

- Main switch (+30) (red protection)
- Contact switch. (+15) (yellow protection)
- Low beam
- Turn light

2.7.3 Steering wheel functions

The steering wheel electronic give the most driver location in a very ergonomic use.



Steering wheel functions:

N°	Function	Conditions / Remarks
1	Starter	Active in gear lever in "P" or "N" Active if < 500 rpm
2	Diff map change 3 maps	Short push to increase differential map number The diff map scrolls rotatory with 3 maps Diff map number is showed on the display screen "driver 1" Map 1: High locking torque Map 2: Medium locking torque Map 3: Medium locking in and high locking out of the corners
3	Safety brake signal	Brake signal activation directly. Possible move the gear lever without push the brake pedal. IMPORTANT: the use of this security button it's under the user responsibility.
4	Radio	Driver voice activation Maintain pushed to talk
5	Rain lights	Short push to toggle on/off
6	Driver fan	Toggle to activate
7		No active
8	Lights	Short push to flash Long push to toggle on/off
9	Wiper	
10	Windscreen water	Push to water splash + wiper scanning
11	Drink	Activates a water pump. Note: Pump not supplied by SSp.



TECHNICAL MANUAL LEON CUP RACER

2.8 Brakes

The following table shows the parts features mounted on the LCR.

Brake car features	Description	Remarks
Front caliper	AP 6P	Special: SEAT Sport
Front disc	362 x 32	Special: SEAT Sport
Front pump	AP 17,3 mm	
Front pads	Galfer RX	25 mm
Rear caliper	AP 2P	
Rear disc	272x10	Solid
Rear pump	AP 22.2 mm	
Rear pads	Galfer RW	
Rear press reducer	Single valve 25 bar	(nominal)
Brake balance	Mechanical	

Notes:

- The front calipers are internally different from the AP std parts. Use always spare parts from the SEAT Leon Cup Racer Parts Catalogue.
- The front discs for the SEAT Cup Racer have 11 bracket lengths. Use always spare parts from the SEAT Leon Cup Racer Parts Catalogue.
- The rear caliper pressure is limited. The brake pressure value showed on the dashboard is previous to the reduction press valve.

Following the brake pump range available.

MASTER CILINDER	Push Rod	Remarks
AP 15 MM	PRT 110	
AP 15.9 MM	PRT 110	
AP 16.8 MM	PRT 110	
AP 17.8 MM	PRT 110	SEA Sport car delivery
AP 19,1 MM	PRT 110	
AP 20,6 MM	PRT 110	
AP 22,2 MM	PRT 110	SEAT Sport car delivery
AP23,8 MM	PRT 110	

Brake balance.

- It is recommended keep the same pump diameter balance.
- The brake balance is mechanic through the remote brake bias adjuster.
- Do not press the brake pedal when you are adjusting the brake balance.
- **On the dashboard screen “mechanic page 1” it’s shown** the front / rear pressure and the balance percentage. The recommended percentage is 60% front. (car delivery)
- Balance value: $\frac{\text{FRONT}}{\text{FRONT} + \text{REAR}} \times 100$

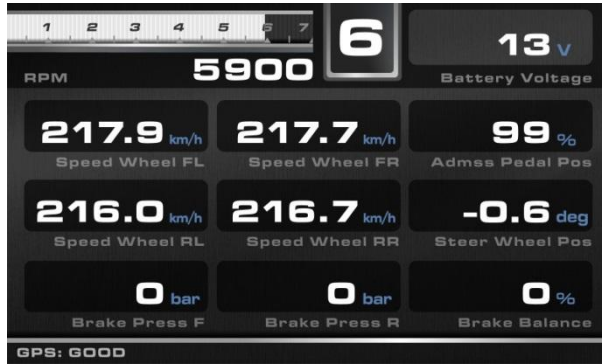

2.9 Dampers and Springs

Front Damper information
STTV technology (Single Tube Twin Valve)
2 – way adjustable
Aluminium outer housing
Upside down cartridge
Friction optimized guide bushings and seals

Front Strut



Bump adjustment:
 The bump adjuster allows 10 clicks.
 Click 0 = complete closed / max. available bump forces
 Click 10 (turn counter clockwise) = complete open / min. available bump forces.

Rebound adjustment:
 The rebound adjuster allows 20 clicks.
 Click 0 = complete closed / max. available rebound forces
 Click 20 (turn counter clockwise) = complete open / min. available rebound forces

Generell Information:

- STTV technology (Single Tube Twin Valve)
- 2 - way adjustable
- Aluminum outer housing
- Upside down cartridge
- Friction optimized guide bushings and seals

Notes:

- Start to count the clicks from close (+) to open.
- Be careful, do not squeeze to close strong the last click.

Rear Damper information
The rear damper is equipped with a 1-Way parallel adjuster.
Each click adjusts the bump and rebound characteristics parallel.

Rear Damper



Adjustment:
The rear damper is equipped with a 1-Way parallel adjuster.
Each click adjusts the bump and rebound characteristics parallel.
Click 0 = complete closed / max. available damping forces.
Click 20 (turn counter clockwise) = complete open / min. available damping forces

- Generell Information:**
- STTV technology (Single Tube Twin Valve)
 - 1 - way parallel adjustable
 - Aluminum body
 - Friction optimized guide bushing and seals

Notes:

- Starts to count the clicks from close (+) to open.
- Be careful, do not squeeze to close strong the last click.

Characteristics and adjustment range of the front and rear struts:

FRONT

REAR

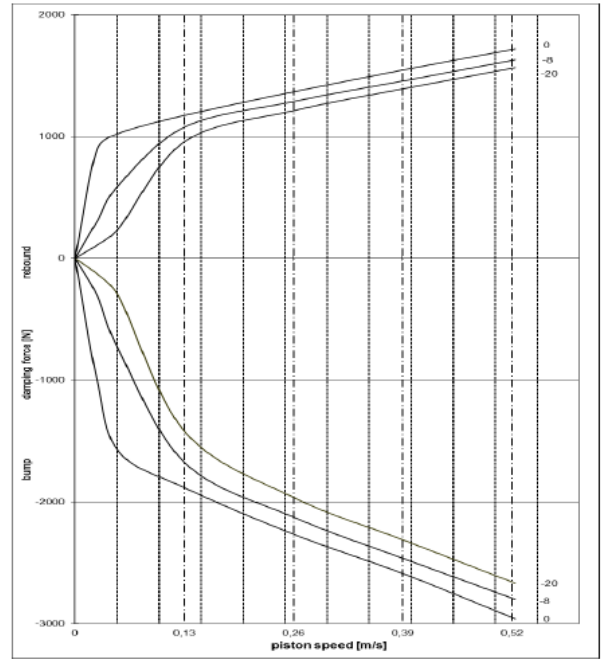
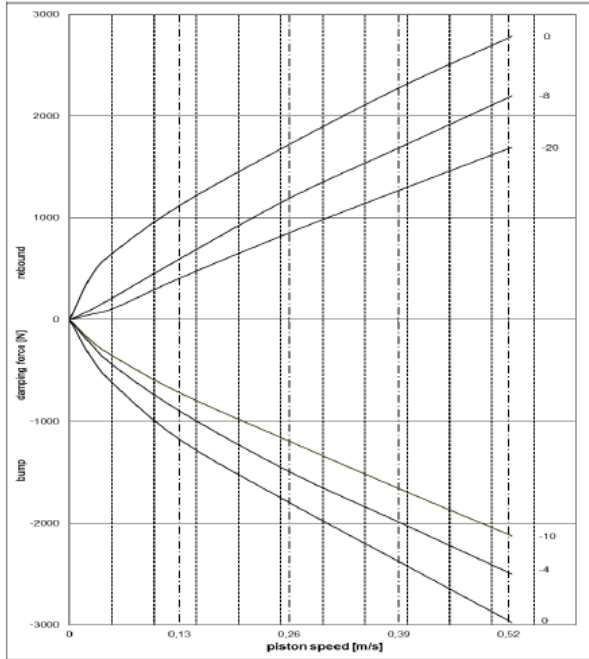

The available springs for front and rear struts are the following:

Measures	Nm	Remark
160-60-120	120	Front use recommended
160-60-110 (car delivery)	110	Front use recommended
160-60-100	100	Front use recommended
160-60-90 (car delivery)	90	Rear use recommended
160-60-80	80	Rear use recommended
160-60-70	70	Rear use recommended

3 SETTING ADJUSTMENTS

3.1 Tire

Tire information	
Rim dimension	10"x 18" ET 36
Rim center lock	5 strut x 112 mm
Eruco Cup Tire brand	DUNLOP
Tire dimension	265/650 R18
Tire press in hot (recommendation)	2.1
Tire use range (recommendation)	(2.0.....2.3)
Minimum cold pressures	1.4 bar front // 1.6 bar rear
Tire temp difference inside/ outside	20°C

Rolling radius vs load
(Camber 4°)

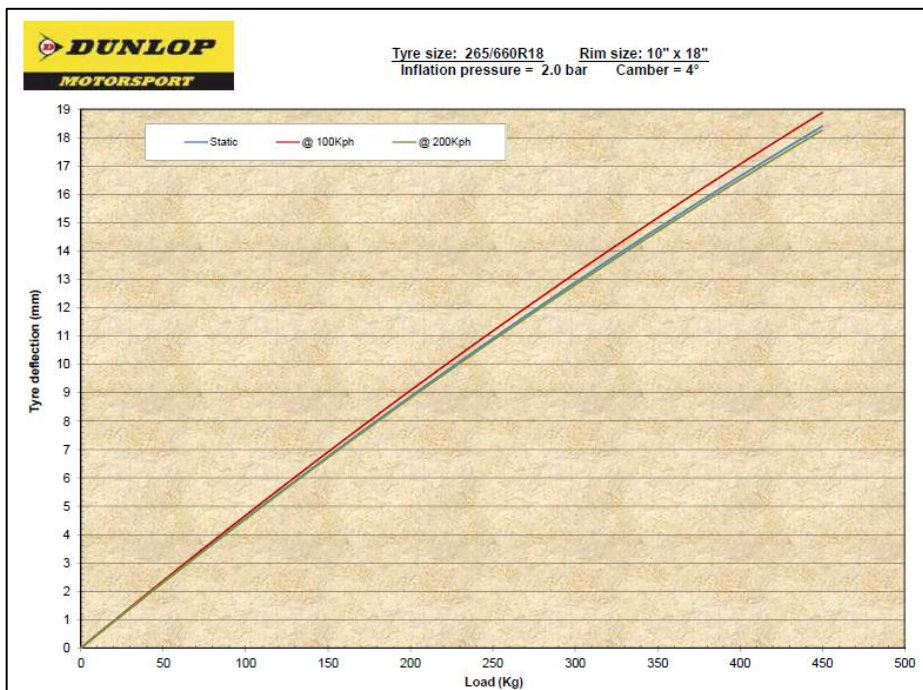
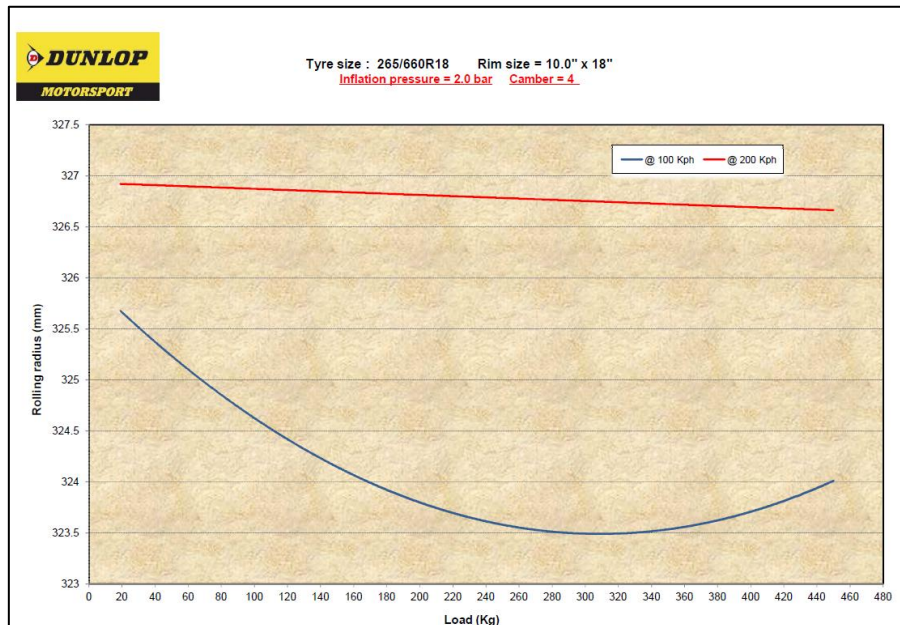

Tyre deflection vs load (Camber 4°)

Safety advice and recommendations

- Ensure minimum hot pressures are adhered to ! (see table below). Stagger cold pressures according to car balance & handling.
- Fit valve dust caps at all times when the car is testing.
- Cold pressures should only be set on tyres that have been shaded from direct sunlight. Do not bleed tyres as the ambient temperature rises!
- After setting the cold pressures, **use any available sunlight** to warm tyres as far as possible before use. This will improve initial grip and lift the internal pressure to reduce sidewall deflection. Again do not bleed tyres if the pressures have risen !
- Remember to raise your cold pressures during evening and night running as these periods are cooler and lap times slower. Consequently you will not get the same hot pressure as daytime and tyres will run with more sidewall deflection.
- On cold tyres, avoid hitting kerbs for the first 2 to 3 laps as pressures have not built up and there is a risk of damaging tyres.
- On new tyres, (especially on aggressive circuits and cold conditions) and where no tyre heaters are used, do two slow laps without sliding, gently increasing lap times. This will ensure the front and rear tyres warm up together and avoid any cold tearing (graining) of tread compound.
- With new tyres, simulate qualifying by doing 7 timed laps --- 2 slow warm up laps, followed by 5 quick laps. Allow tyres to cool and then do the required long run.
- Tyres are non-directional and so can be changed from side to side and / or front to back once they have been run.

	Cold (guide only)		Hot (minimum)	
	psi	bar	psi	bar
Slicks	22	1.5	29	2
Wets	25	1.7	29	2



Motorsport Technical (UK)
2013



Please respect this advice to avoid excessive sidewall distortion and the risk of deflation

4 Front suspension

	front	rear
Wheel ratio	1mm wheel / 0,9mm damper	1:1
Damper travel	115mm	118mm

4.1 Anti roll bars

Two front anti roll bar available: 22x2 and 22x3. [Production cars: 22x3.](#)

FRONT ARB		
OD (mm)	22	22
Thickness (mm)	2,0	3,0
Chassis Roll Stifness from ARB		
Hard (Nm/°Chassis)	1548	2021
Mid (Nm/°Chassis)	991	1293
Soft (Nm/°Chassis)	688	898

Two rear anti roll bar available: 22x3 and 22x4. [Production cars: 22x3.](#)

REAR ARB		
OD (mm)	22	22
Thickness (mm)	3,0	4,0
Chassis Roll Stifness from ARB		
Hard (Nm/°Chassis)	1252	1454
Mid (Nm/°Chassis)	1061	1232
Soft (Nm/°Chassis)	898	1043

4.2 Kinematics

FRONT

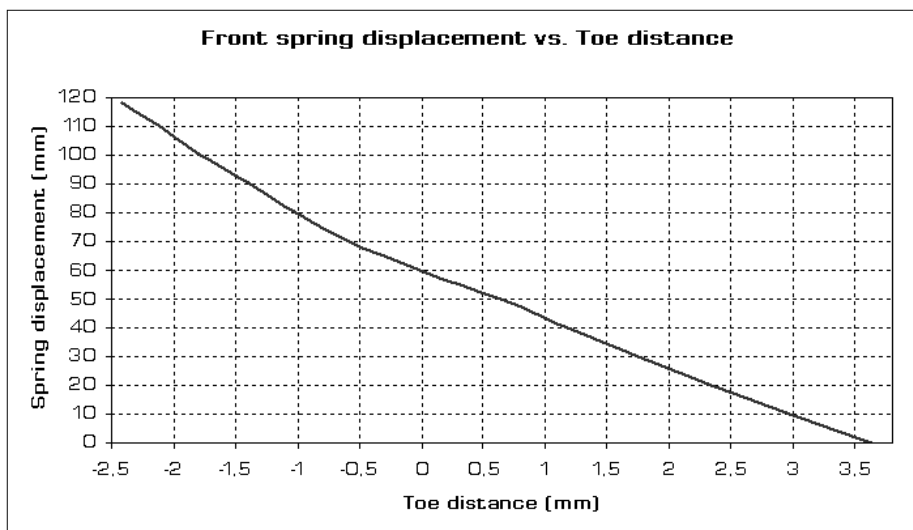

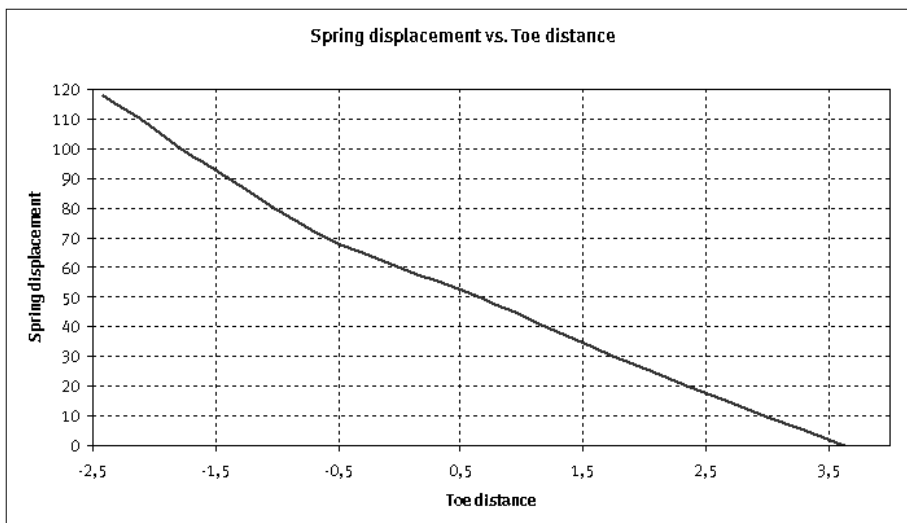
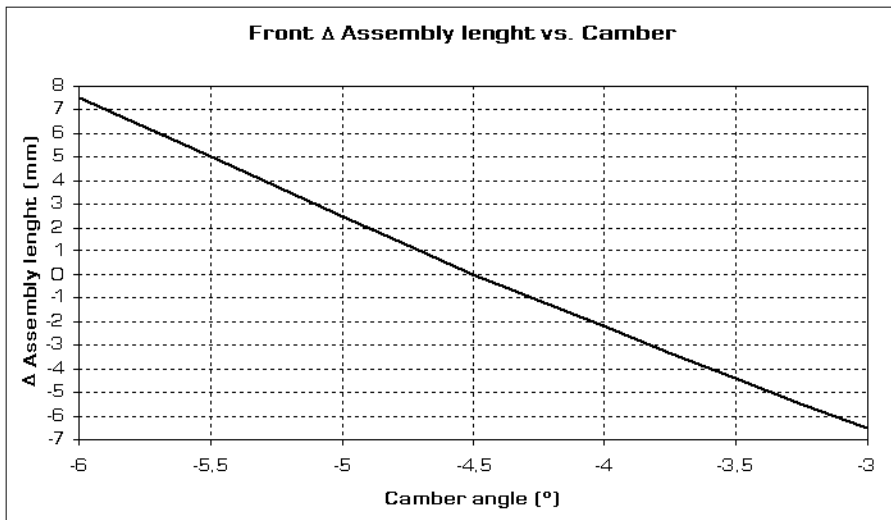
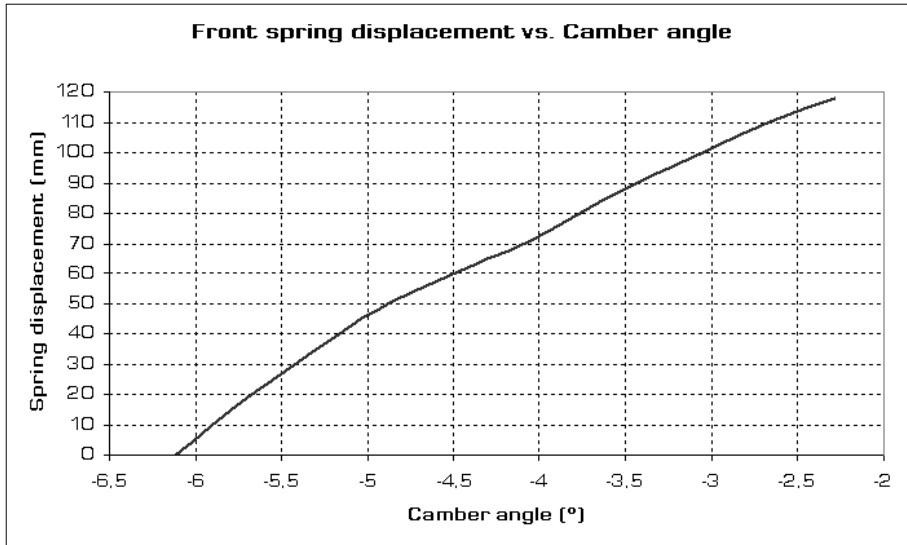

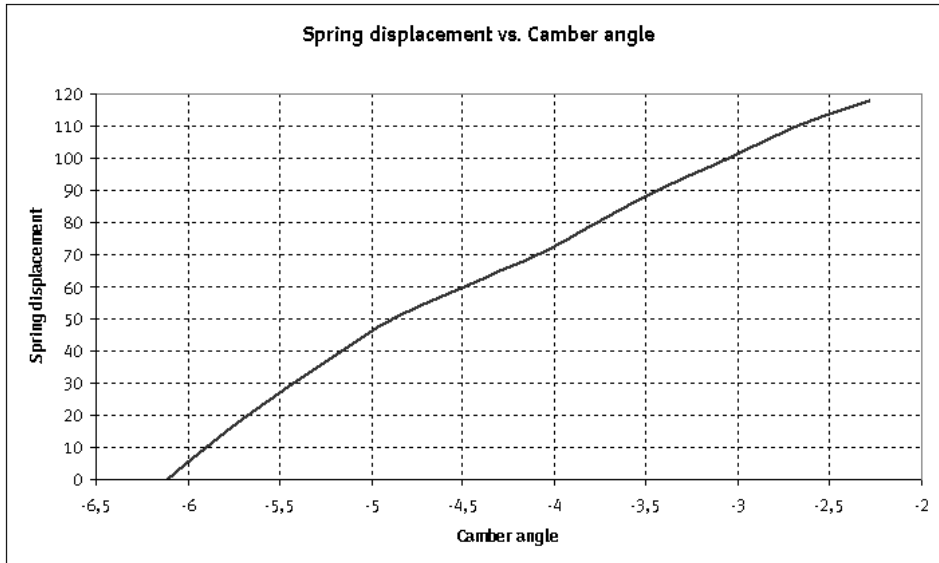

REAR

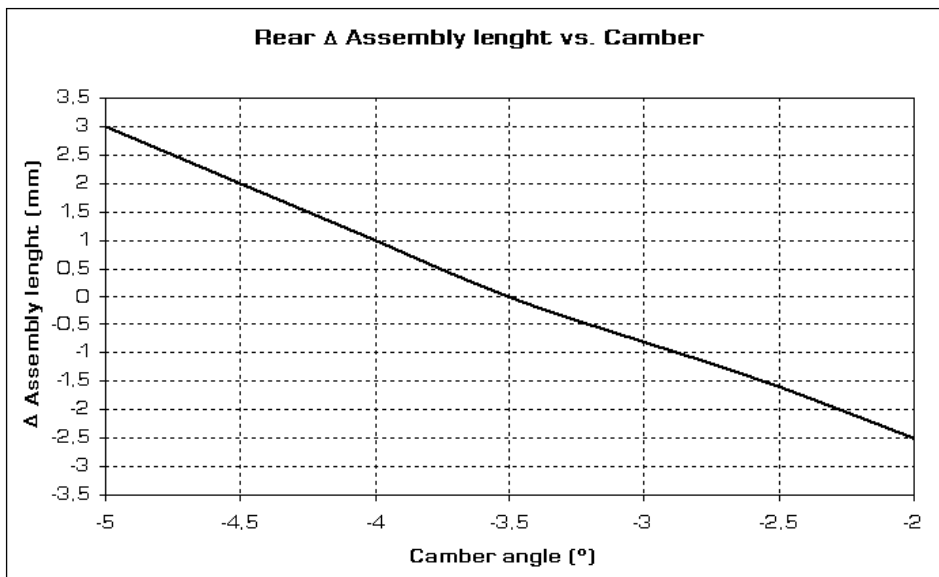

4.2.1 Front Camber and Toe adjustment

Underneath of the front wishbone there is a bolt to control the adjustment movement. Unblock the four screws that are fixing the camber regulator plate and proceed at the camber adjustment.

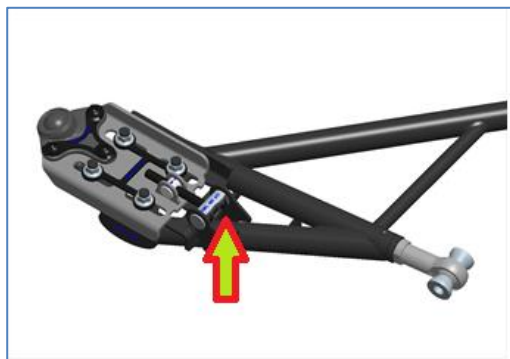

Notes:

- After any intervention, fix the camber regulator plate bolts in the right tighten.

- Maintain the camber regulation plate clean and little oiled between plates.

Following a table for the Font Camber bolt regulation turn vs gain vs toe

Camber	Toe regulation	Wishbone regulation 1,5 turns = 10' camber
-6	10,5 Turns	13 Turns
-5,5	7 Turns	8,3 Turns
-5	3,5 Turns	4,5 Turns
-4,5	0	0
-4	-3,5 Turns	-4 Turns
-3,5	-6,5 Turns	-8 Turns
3	-10 Turns	-12,5 Turns

4.3 Rear suspension

4.3.1 Rear Camber regulation

The rear camber regulation is controlled through the “boomerang” arm.

The rear Camber regulation does not have relation with the toe movement, so you can change rear camber without any toe movement.



Note:

- After the camber adjustment job, check that the uniball rest placed in the middle of the its housing.

Rear Camber value vs rear camber regulation screw turn.

Camber	Camber arm regulation
-2	1,5 Turns
-2,5	1 Turns
-3	0,5 Turns
-3,5	0
-4	-0,5 Turns
-4,5	-1 Turns
-5	-1,5 Turns

4.5 Alignment

The steering rack is electric.

To fix the steering rack to align the car set up it is necessary to fix the rack through the steering wheel. This job could be done with different tools. The most useful is using two straps going through the steering wheel and the roll cage.

The use of a rack centering tool is not recommended because is difficult to get the steering angle sensor at “0 deg”. The most important is to obtain the toe alignment with the sensor at “0 deg”.

Proceed as following:

- Switch on main and ignition switches.
- Turn left and right to get the steer signal.
- Fix the steering wheel with straps when the steer angle is “0 deg”
- Switch off the ignition and main.
- You can now proceed at the alignment jobs.

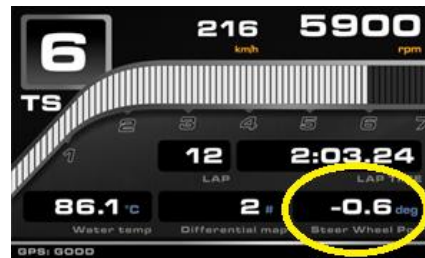

Note:

With this process the steering angle signal will be at 0 deg, with the wheels aligned. This fact is very important for the steering assistance and for the electronic slip differential behaviour.

5 ELECTRIC

5.1 General information

The car have installed the following modules:

Electronic MODULES	Remarks	Place
ECU	Continental /Symos 18.1	Engine bay
Mechatronic	VW	Inside gear box
Electronic slip differential	BorgWarner	FDX (external)
Low fuel pump control	PWM control module	Fuel tank (external)
Electronic Steering rack	VW	Front subframe
ESP unit	Continental (not hydraulic connexion for cup cars)	Cockpit
Gateway	VW	Cockpit
Black box	Audi	Cockpit
MXG display / logger	AIM	Cockpit
Fuse box	SEAT Sport	Cockpit
Driver module	SEAT Sport	Cockpit
Transponder	XXX	Engine bay

5.2 Modules

MODULES BASED IN SERIES	Engine	Mechatronic	Elec. Slip diff.	Low fuel pump	Steering rack	ESP	Gateway
Specific software/ mapping:	Yes	Yes	Yes	No	Yes	No	Yes
Specific codifications:	Yes	Yes	Yes	No	Yes	yes	yes
Interchangeable between cars:	Yes	No	No	Yes	Yes	Yes	Yes
Spare part ready for plug and play:	Yes	No	Yes	Yes	Yes	Yes	Yes
*UDS diagnosis (VW diagnosis):	Yes	Yes	Yes	Yes	Yes	Yes	Yes
Modification allowed:	No	No	No	No	No	No	No

Notes:

- Use always spare parts from SEAT Sport. Although the mentioned parts hardware are derived from series cars, the software and codifications are different and already modified for SEAT Sport.
- UDS: All series modules used on the SEAT Leon Cup Racer are based in the MQB platform. Through the tool "ODIS", available on the VW Group dealers, it is possible to diagnostic any malfunction.

5.3 Data Logger

The MXG display features a high contrast 7" TFT display, fully configurable by dedicated software. The SEAT Leon Cup MXG configuration has 5 page as well as CAN and math channels.

Swapping between pages can be managed pushing one or two pushbuttons.

An ambient light sensor keeps the backlight at optimum brightness levels. The MXG is in association with the GateWay sending information that other devices needs so it's part of the electric architecture.



Features	Remarks
BEACON	The MXG system don't use beacon. Only GPS signal.
Circuit config.	<ul style="list-style-type: none"> ➤ Through the "RaceStudio3" with "Track_Manager" program it's possible to activate all circuits in the world. ➤ There is possible to create your own circuit with the program.

Architecture Leon Cup Racer: All electronic modules are connected by CAN Bus and LIN_Bus. Following the LCR CAN scheme view:

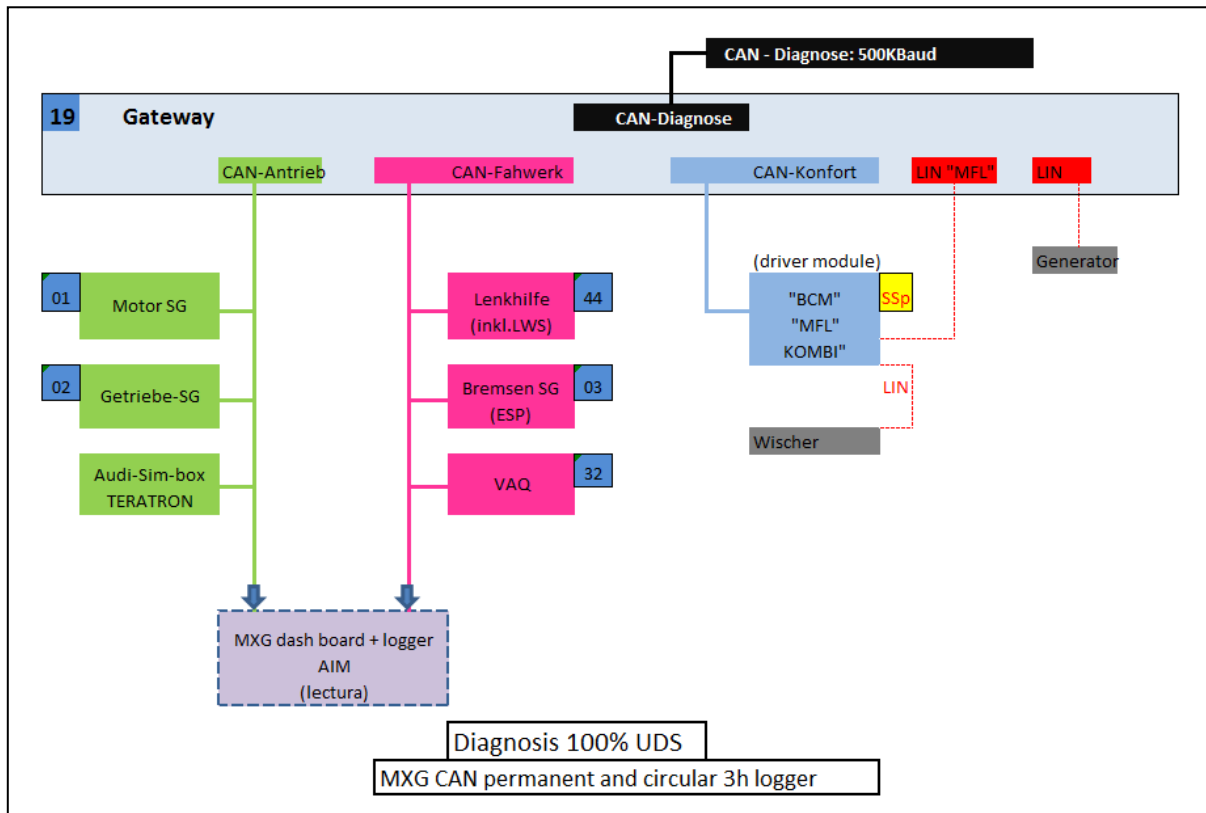

MXG logger data acquisition channels information:

CHANNEL NAME	DATA ACQ NAME	UNIT	SCALE
P_turbo	P_TURBO	Pressure (bar)	1...2.2
T_air	T_ENG_AIR	Temperature (°C)	
T_oil	T_ENG_OIL	Temperature (°C)	
T_water	T_ENG_WATER	Temperature (°C)	
T_extern	T_AIR	Temperature (°C)	Temp
RPM	RPM_ENG	rpm	760...6800
Brake	FLAG_BRAKE	on/off	0.. 1 (1= braking)
ANA1	P_BRK_FRONT	Pressure (bar)	0...140
ANA2	P_BRK_REAR	Pressure (bar)	0...140
ANA5	P_ENG_OIL	Pressure (bar)	1.5... 4
ANA6	P_ENG_FUEL	Pressure (bar)	3.5... 7
ANA7	FUEL_LEVEL	lts	0... 55
Pedal	POS_PEDAL	Load %	0...100
Gear_Lever	POS_GBX_LEVER	number	0=Init, 5=D, 6=N, 7=R, 8=P, 10=Tipp+, 11=Tipp-, 12=S, 14=Tipp Pos., 15=Failure
DSG Mode	POS_GBX	number	0=Init, 5=P, 6=R, 7=N, 8=D, 9=S, 13=Tipp in S, 14=Tipp in D, 15=Failure
Gear	GEAR	number	0=N, 1=1°, 2=2°, 3=3°, 4=4°, 5=5°, 6=6°, 9=P, 10=S, 11=D/E, 12=Intermediate, 13=Rev, 14=undefined, 15=failure
Tip Down	TIP_DOWN	sign	1=Tip Down
Tip Up	TIP_UP	sign	1=Tip Up
Diff Map	POS_DIF_MAP	number	1 - 2 - 3
Gearbox temp.	T_GBX_OIL	Temperature (°C)	10...138
Y_Acc	G_CH_Y	acceleration (g)	-1,27...1,27g
X_Acc	G_CH_X	acceleration (g)	-1,27...1,27g
YawRate	W_CH	Angular speed (°/s)	0..163,82 Rad/s
Speed_RL	V_WHL_RL	Velocity (kph)	0...250
Speed_RR	V_WHL_RR	Velocity (kph)	0...250
Speed_FL	V_WHL_FL	Velocity (kph)	0...250
Speed_FR	V_WHL_FR	Velocity (kph)	0...250
Abs Steer angle	A_STE_Abs	Angle (°)	0..800 °
FuseState5	FLAG_FBX_F5	number	
FuseState4	FLAG_FBX_F4	number	
FuseState3	FLAG_FBX_F3	number	
FuseState2	FLAG_FBX_F2	number	
FuseState1	FLAG_FBX_F1	number	
Battery Voltage		mV	0 – 14.700 mV

Form AIM "GPS"	Unit	
GPS_Speed	kph	
GPS_Nsat	**	N° of satelits on
GPS_LatACC	g	
GPS_LonACC	g	
GPS_Slope	deg	
GPS_Heading	deg	
GPS_Gyro	deg/s	
_GPS_Altitude	m	

 X_Acc and Y_Acc form the ESP series unit have the limit under the max value that car can reach. Use the Longitudinal and Lateral Acceleration from GPS signal to set up the car.

Following is shown the standard typical approximate values that you could expect. (Conditions at 20° C air temperature).

Cannel measures	Eadle speed	Std use values at Tair 20°C	Máximum value
P_TURBO	1 bar	2.2 bar	2.2 bar
P_ENG_FUEL	4.8 bar	5.8 bar	7 bar
P_ENG_OIL	1.5 bar	4 bar	5 bar
T_ENG_AIR	<	42°C	>75°C
T_ENG_OIL	<	122°C	>147°C
T_ENG_WATER	<	95°C	>120°C
T_GBX_OIL	<	114°C	>138°C

Note:

- The "maximum value" underlined in orange shows the value before performance restrictions or protection.

5.3.1 MXG channel expansion scheme

MXG logger data expansion channels:

Scheme 1: Data logger standard connection scheme. (car delivery)

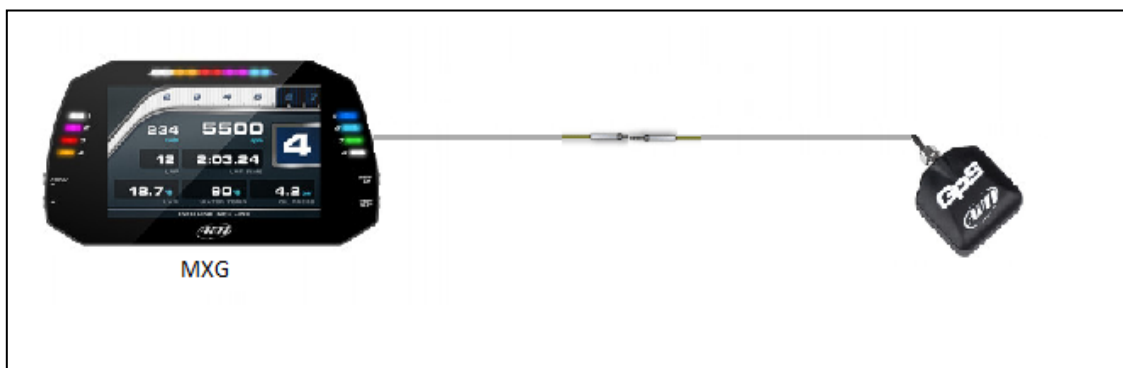

Scheme 2: Data logger connection scheme with Smarty cam and expansion module.

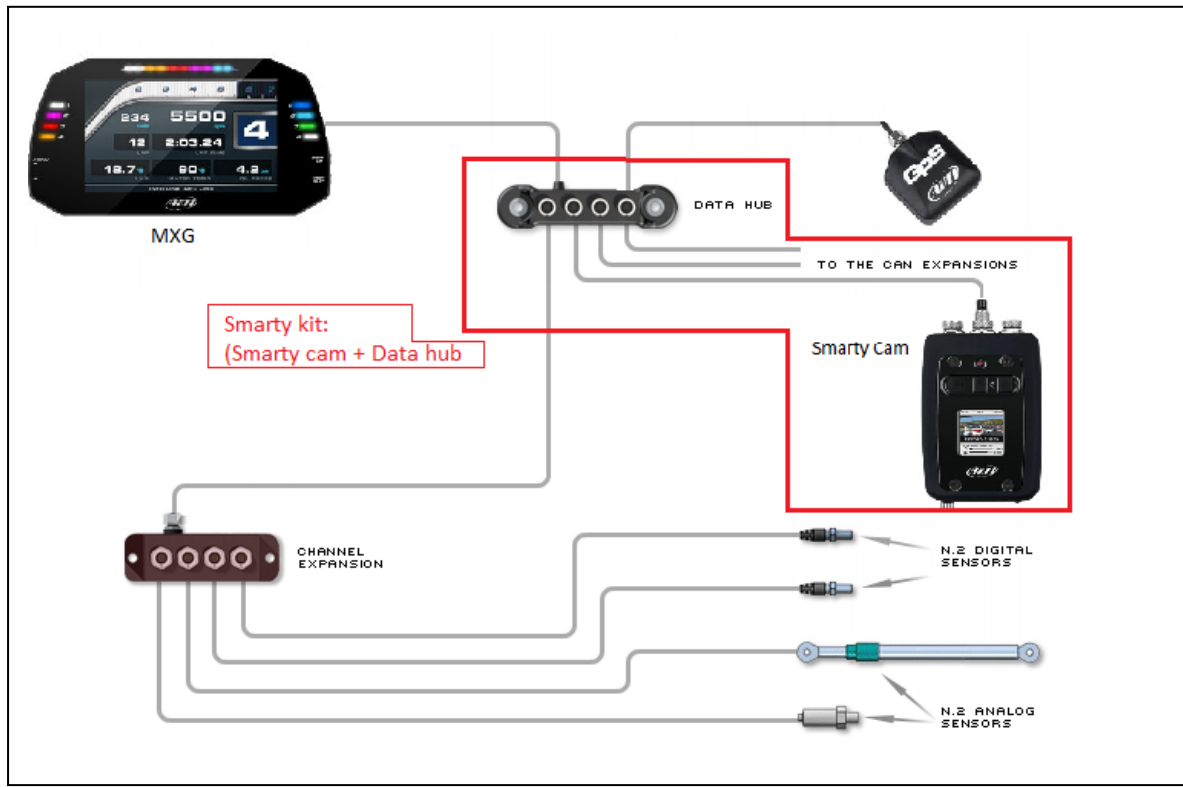

Features	Remarks
BEACON	The MXG system use Only GPS signal.
Circuit config.	<ul style="list-style-type: none"> ➤ Through the "RaceStudio3" with/or "Track Manager" programs it's possible to activate all circuits in the world. ➤ There is possible to create your own circuit with the program.
Extra sensors*	<ul style="list-style-type: none"> ➤ In case you want to add extra sensors, you have to connect them to an "Expansion module" as shown in the scheme "2" ➤ Any extra sensor have to be connected through the AIM DATA HUB + CHANNEL EXPANSION (scheme 2).

Notes:

- For the SEAT Cup participants: Any extra sensor have to be connected through AIM system
- Channel expansion module and sensors only available through AIM dealers.

5.4 Display

5.4.1 Driver pages:

The display contains 5 pages classified in 2 families.

Family A: 2 driver “pages”

Family B: 3 mechanic “pages”

Driver screen 1 content:

Engine speed: Current engine speed rpm.

Wheel Speed: Current W. speed. (FL)

Gear: Correspond to gear box ratios engaged.

P= Parking / R= reverse / N= neutral / n°: 1-2-3-4-5-6 = ratios.

Gear lever position (TS): Current gear lever position. (P, R, N, D, S, Tip)

Lap time: Current lap time (stay displayed 10s after having being cut)

Lap: Number of completed laps during the run.

Diff map: Electronic slip differential map selected. 1-2-3.

Steer angle: Current steer angle signal.

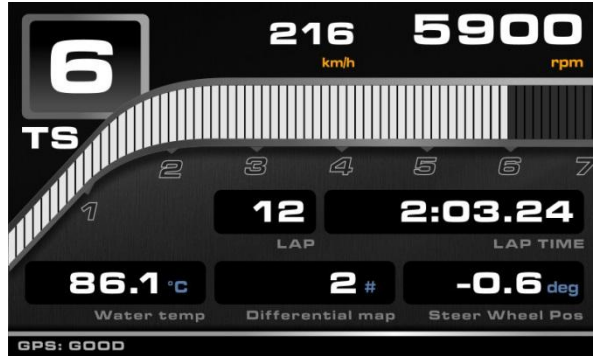

Driver screen 2 content:

Same than “Driver 1” page but different in the 3 bottom windows.

This window is more focus to the endurance races

Fuel level: Current fuel quantity.

Water temp: Current water temp

Oil press: The current engine oil press

Mechanic screens:

The mechanic screen 1, 2, 3, contains the information necessary to control all the car areas when the car is on pits or running.

It's a big help when laptop is not available during the start procedure or after car reparation.

Screen 1, Engine: rpm, Gear, Twater, Toil (engine), Toil (gearbox), Poi, Boot, Battery, Xxxx

Screen 2, Chassis: rpm, FL speed, FR speed, RL speed, RR speed, P-brake front, P-brake rear, Brake blance (%), Steer angle, Battery

Scree 3, Gearbox: rpm, Gear engaged, Gear lever pos. Twater, Tip, Tip down, Steer angle, Diff map, N° of satelits actives





5.4.2 Display alarms and shift lights

Eight configurable RGB alarm LEDs.

Select solid alarm or flashing one – and the flashing frequency, choose to have an accompanying text message and set the alarm priorities.

The SEAT Leon Cup is delivered in the following configurations:

LED Alarm Number	Channel condition	
1	Oil Pressure ≤ 0.7 ba	Yellow
2	Oil Pressure2 ≤ 0.5 bar	Red
3	Oil Pressure2 ≤ 0.5 bar	
4	Fuel Pressure ≤ 1.50 bar	Yellow
5	Water Temp $\geq 100^{\circ}\text{C}$	Yellow
6	Water Temp2 $\geq 115^{\circ}\text{C}$	Red
7	Gearbox Temp $\geq 135^{\circ}$	White
8	Air Temp $\geq 65^{\circ}\text{C}$	Blue

SHIFT LIGHT Led Number	Condition on RPM value	
1	rpm ≥ 6100	Green
2	rpm ≥ 6100	Green
3	rpm ≥ 6100	Green
4	rpm ≥ 6300	Yellow
5	rpm ≥ 6300	Yellow
6	rpm ≥ 6300	Yellow
7	rpm ≥ 6500	Red
8	rpm ≥ 6500	Red
9	rpm ≥ 6500	Red
10	rpm ≥ 6500	Red

5.5 Transponder:

Transponder	Remarks
Availability	All Eurocup participants have installed // rest: purchase order
Type	Radio frequency
Energy	Connected to the car 12v (with fuse)
Position	See drawing // right side // body shell support ready.

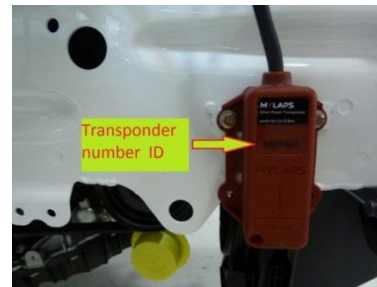
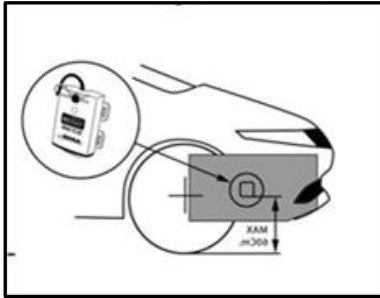

Note:

- All SEAT Leon Cup cars bought to participate on the SEAT Leon Eurocup will be provided with the transponder mounted.
- The cars bought for other championships, the owners can decide acquire the transponder in SEAT Sport or not. Car will be provided without transponder.

5.6 Extra connectors:

Behind the driver seat there are the two wiring connectors in connection with the steering wheel module. Radio and drink. The radio connector scheme is the following:

Radio		
Main loom reference connector:		4D0 972 704
matching connector:		1J0 972 714
pinout		Terminal
1	+30 up to 8A	FS 2,8 x 0,8 (*)
2	GND	FS 2,8 x 0,8 (*)
3	PTT	FS 2,8 x 0,8 (*)
4	PTT	FS 2,8 x 0,8 (*)

There is an auxiliary power supply connector to use for any requirement. This connector is placed in the driver cockpit above the central tunnel (front).

Auxiliar power supply		
Main loom reference connector:		4D0 972 704
matching connector:		1J0 972 714
pinout		Terminal
1	+30 up to 8A	FS 2,8 x 0,8 (*)
2	+15 up to 5A	FS 2,8 x 0,8 (*)
3	GND	FS 2,8 x 0,8 (*)
4	GND	FS 2,8 x 0,8 (*)

6 Bodywork & aero

6.1 Material of bodywork panel.

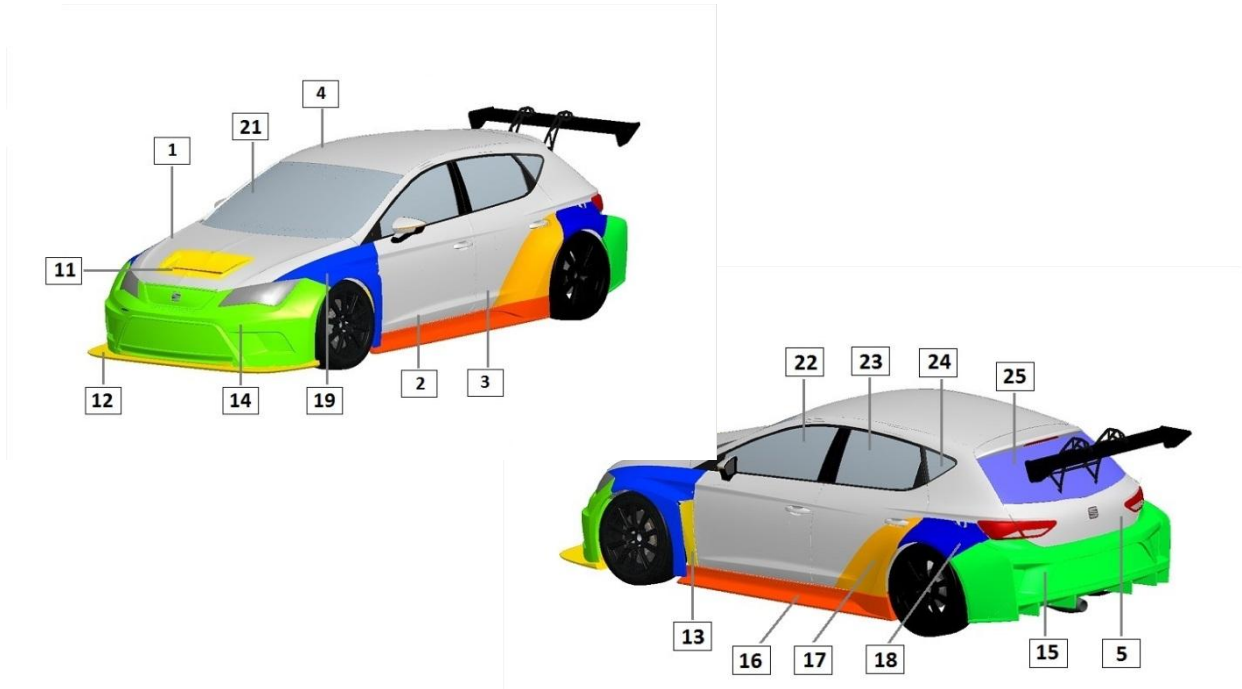

PART NUMBER	DESCRIPTION	MATERIAL
01	BONNET	STEEL
02	LEFT / RIGHT FRONT BONNET	STEEL
03	LEFT RIGHT REAR BONNET	STEEL
04	ROOF	STEEL
05	LUGGAGE COMPARTMENT COVER	STEEL
11	BONNET OPPENING	CARBON
12	FRON SPLITTER	CARBON
13	FENDER AIR EXIT	CARBON
14	FRONT BUMPER	FIBER GLASS
15	REAT BUMPER	FIBER GLASS
16	LEFT /RIGHT SILL TRIM PANEL	PLASTIC
17	LEFT / RIGHT REAR DOOR EXTENSION	PLASTIC
18	LEFT / RIGHT REAR FENDER EXTENSION	CARBON (painted)
19	LEFT / RIGHT FRONT FENDER	CARBON (paintet)
21	WINSCREEN	GLASS
22	LEFT / RIGHT FRONT DOOR WINDOW	GLASS
23	LEFT / RIGHT REAR DOOR WINDOW	GLASS
24	LEFT / RIGHT REAR TRIANGLE WINDOW	PLASTIC
25	REAR WINDOW	PLASTIC

Notes:

- All reparations have to be carrying out without any modification or part addition.
- All aerodynamic parts must be fixed exactly like the standard car.
- Any damaged aerodynamic part due to any matter must be replaced

6.2 Rear wing

The rear wing has extensive regulation.

Zero is a standard setting for the car. 5° have considerable influence on the rear downforce.

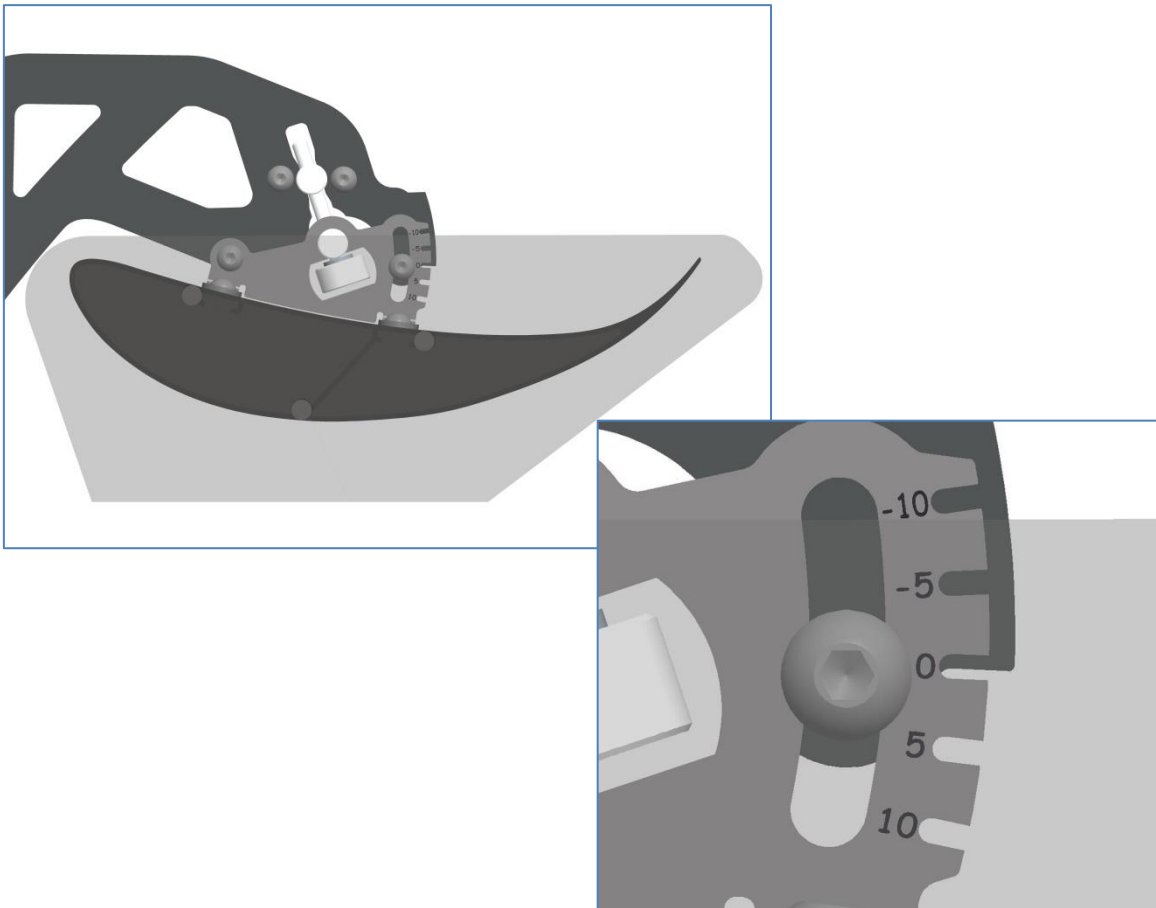

7 SAFETY

SAFETY	Remarks	Images
AIR JACK	<p>3 Air Jacks on the car Max press 30 bar</p> <p><u>Safety:</u> Safety Props: For any job under the car Use ALWAYS the air jack Safety Props. (x3)</p>	
EXTINGUISHER	<p>Material: Aluminium Weight: 6.2 kg Activation: Electric Use: Cockpit and engine bay</p> <p><u>Safety:</u> Check the inner press bottle. Have to be in the green area. Fire extinguisher system: Check always that the 9v inner battery is in good conditions. Do not forget to put the toggle in “on” when car is running.</p>	
BACKET	<p>FIA Homologated 8855 – 1999 Gel coated fiberglass shell W side fixing points HANS Compatible</p> <p><u>Safety:</u> Check the homologation label “expiry date” period. Check ALWAYS the fixations Change if big crash.</p>	
SAFETY BELT	<p><u>Safety:</u> Check always the fixations are well fixed Check the homologation label “expiry date” period.. Check always the driver is strongly fixed.</p>	

8 Parts mileage

ENGINE	Inspection	Service	Change	Remark
Engine		10.000		Serviced by SEAT Sport
Spark plug			2.000	Use original parts only
Engine oil			1.000	Use recommended oil
Engine oil filter			1.000	Use original parts only
Cotton air filter	Once x event	Once x event	season	
Bell poli V	Once x event		2.000	

TRANSMISSION	Inspection	Service / km	Change	Remark
Gear box		10.000		Serviced by SEAT Sport
Oil gear box			5.000	Use original parts only
Gbx oil filter			5.000	
FDX		10.000		Serviced by SEAT Sport
Oil FDX			5.000	
Drive shaft	Once x event	5.000	10.000	

Front axle	Inspection	Service / km	Change	Remark
Front dampers		5.000 / 1 year		Seat Sport service
Ball joints	Once x event		5.000	Always check tolerance
Steering rod inner joint	Once x event		5.000	Always check tolerance
Steering rack			15.000	
Wheel hub	Once x event		10.000	Change when noise
Front Discs	Once x event		1.500	Change when cracks
Dsics bell			5.000	
Brake balance bar	Once x event	4.000		

Rear axle	inspection	Service / km	Change	Remark
Rear dampers		5.000 / 1 year		Seat Sport service
Ball joints	Once x event		5.000	Always check tolerance
Wheel hub	Once x event		10.000	Change when noise
Rear Discs (solid)			1.500	
Wheel nuts			3.000	

Seurity parts	Service / km	Change	Remark
Extinguisher	5 years		Service in SSp or OMP
Bucket		5 years	
Safety Belts		5 years	

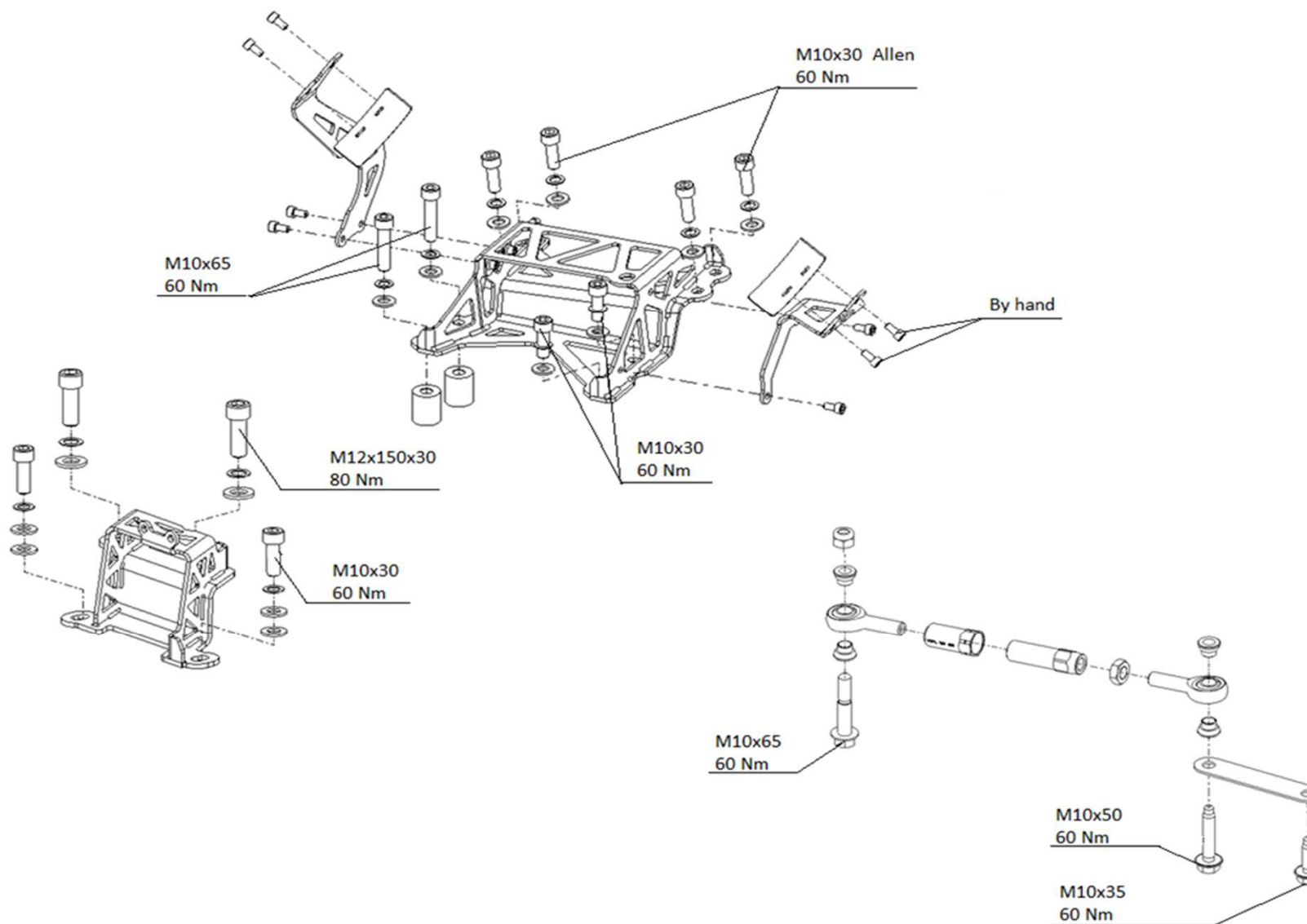
Unterlagen
References

© SEAT SPORT behält sich alle Rechte vor. Das gilt insbesondere fuer Erfindungsrechte, Know-how, Urheberrechte und Namensrechte, sowie fuer das Recht, dieses als gewerbliche Schutzrechte anzumelden. Jede Verfuugungsbefugnis ist. Están reservados todos los derechos de disposición, en especial a copiar o distribuir.

© All rights remain with SEAT SPORT. This applies especially to rights of invention, know-how, copyrights and rights to name as well as for the right to patent these as commercial protective rights. All rights of disposition, particularly for copying or distributing, reserved.

Bemerkungen / Notes

Nr. No.	Datum Date	NAME	Genehmigt Appr.	Beschreibung der Aenderung und Aenderungsterminschlüssel Revision record and change date code	Typ-Pruef-Dok. und Typ-Pruef-Nr./ Type-appr.- doc and type approval number	CAD-System und Verwaltungssystem - Schlüssel CAD-system and administration code	Sicherheits-Dok Safety-doc.
	23/04/14	OSN	ok	Edición		ProE	Konst.Verantw./Design resp.
					Benennung	Engine Brackets	Name A. Almirall
					Title	Engine Brackets	Abt./Dept. O.T.
					EA-Nr. / eng. proj. no.	V3FL	Tel.
							Gez./Drawn ProE
							Blatt/sheet 001
							Format/D.size A3

Unterlagen
References

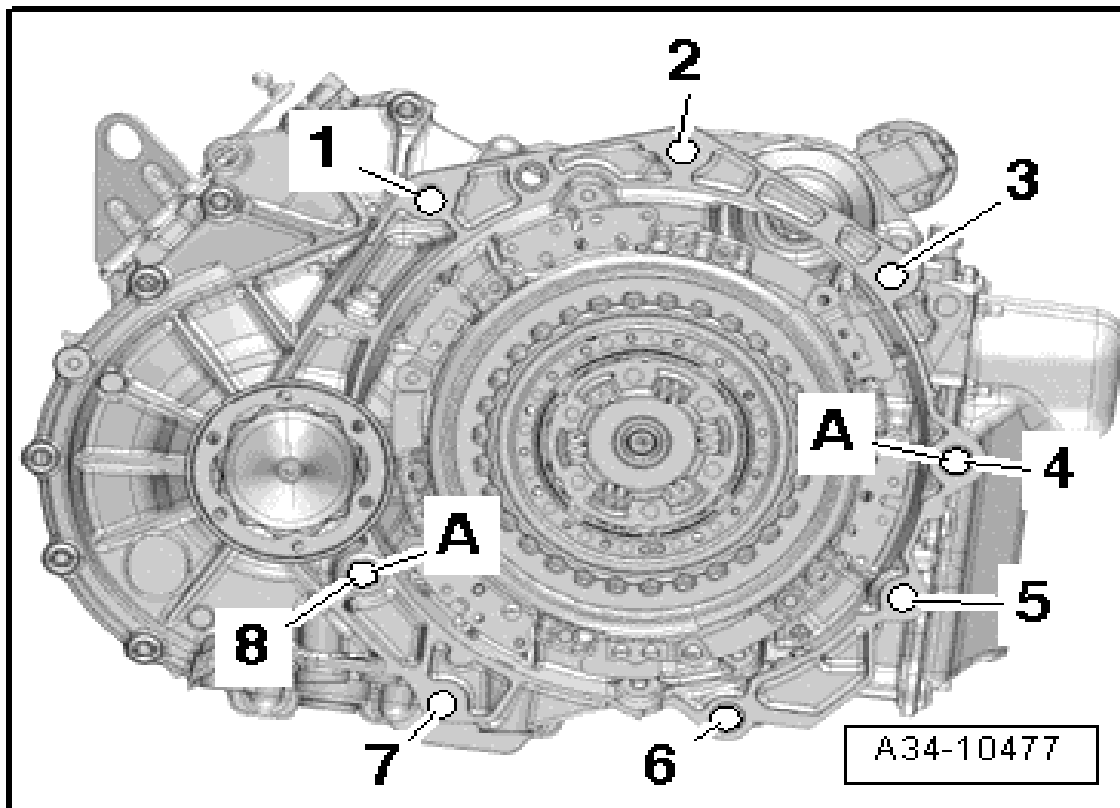

Pos	Thingten	Info
1, 2, 3*, 4	80 Nm	M12x55
5, 6, 7	40 Nm	M10x50
8	80 Nm	M12x65
A	Centering	
3*	Acces rear starter	

© SEAT SPORT behält sich alle Rechte vor. Das gilt insbesondere fuer Erfindungsrechte, Know-how, Urheberrechte und Namensrechte, sowie fuer das Recht, dieses als gewerbliche Schutzrechte anzumelden. Jede Verfuugungsbefugnis ist. Están reservados todos los derechos de disposición, en especial a copiar o distribuir. © All rights remain with SEAT SPORT. This applies especially to rights of invention, know-how, copyrights and rights to name as well as for the right to patent these as commercial protective rights. All rights of disposition, particularly for copying or distributing, reserved.	Nr. No.	Datum Date	NAME	Genehmigt Appr.	Beschreibung der Aenderung und Aenderungsterminschiussel Revision record and change date code	Typ-Pruef-Dok. und Typ-Pruef-Nr./ Type-appr.-doc and type approval number	CAD-System und Verwaltungssystem - Schluessel CAD-system and administration code	Sicherheits-Dok Safety-doc.
		23/04/14	OSN	ok	Edición	Benennung Gear Box	ProE	Konst.Verantw./Design resp. Name A. Almirall
Bemerkungen / Notes						Title Gear Box		Abt./Dept. O.T.
						EA-Nr. / eng. proj. no.	V3FL	Tel. Gez./Drawn ProE
							Blatt/sheet 002	Format/D.size A3

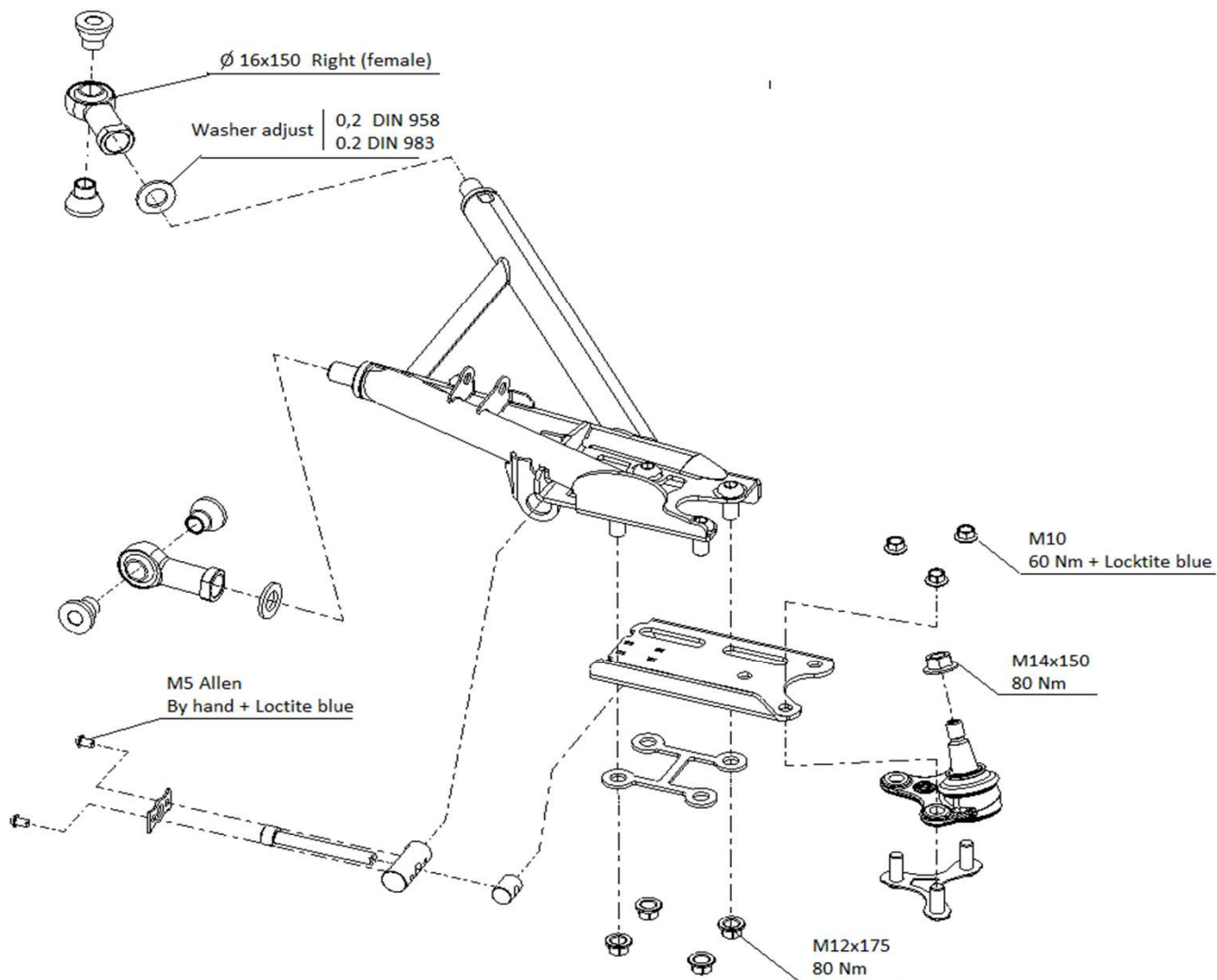
Unterlagen
References

© SEAT SPORT behält sich alle Rechte vor. Das gilt insbesondere fuer Erfindungsrechte, Know-how, Urheberrechte und Namensrechte, sowie fuer das Recht, dieses als gewerbliche Schutzrechte anzumelden. Jede Verfuugungsbezugnis ist. Están reservados todos los derechos de disposición, en especial a copiar o distribuir.

© All rights remain with SEAT SPORT. This applies especially to rights of invention, know-how, copyrights and rights to name as well as for the right to patent these as commercial protective rights. All rights of disposition, particularly for copying or distributing, reserved.

Bemerkungen / Notes

Nr. No.	Datum Date	NAME	Genehmigt Appr.	Beschreibung der Aenderung und Aenderungsterminschiussel Revision record and change date code	Typ-Pruef-Dok. und Typ-Pruef-Nr./ Type-appr.-doc and type approval number	CAD-System und Verwaltungssystem - Schluessel CAD-system and administration code	Sicherheits-Dok Safety-doc.
	23/04/14	OSN	ok	Edición		ProE	Konst.Verantw./Design resp.
					Benennung	Front Wishbone	Name A. Almirall
					Title	Front Axle	Abt./Dept. O.T.
					EA-Nr. / eng. proj. no.	V3FL	Gez./Drawn ProE
							Blatt/sheet 004
							Format/D.size A3

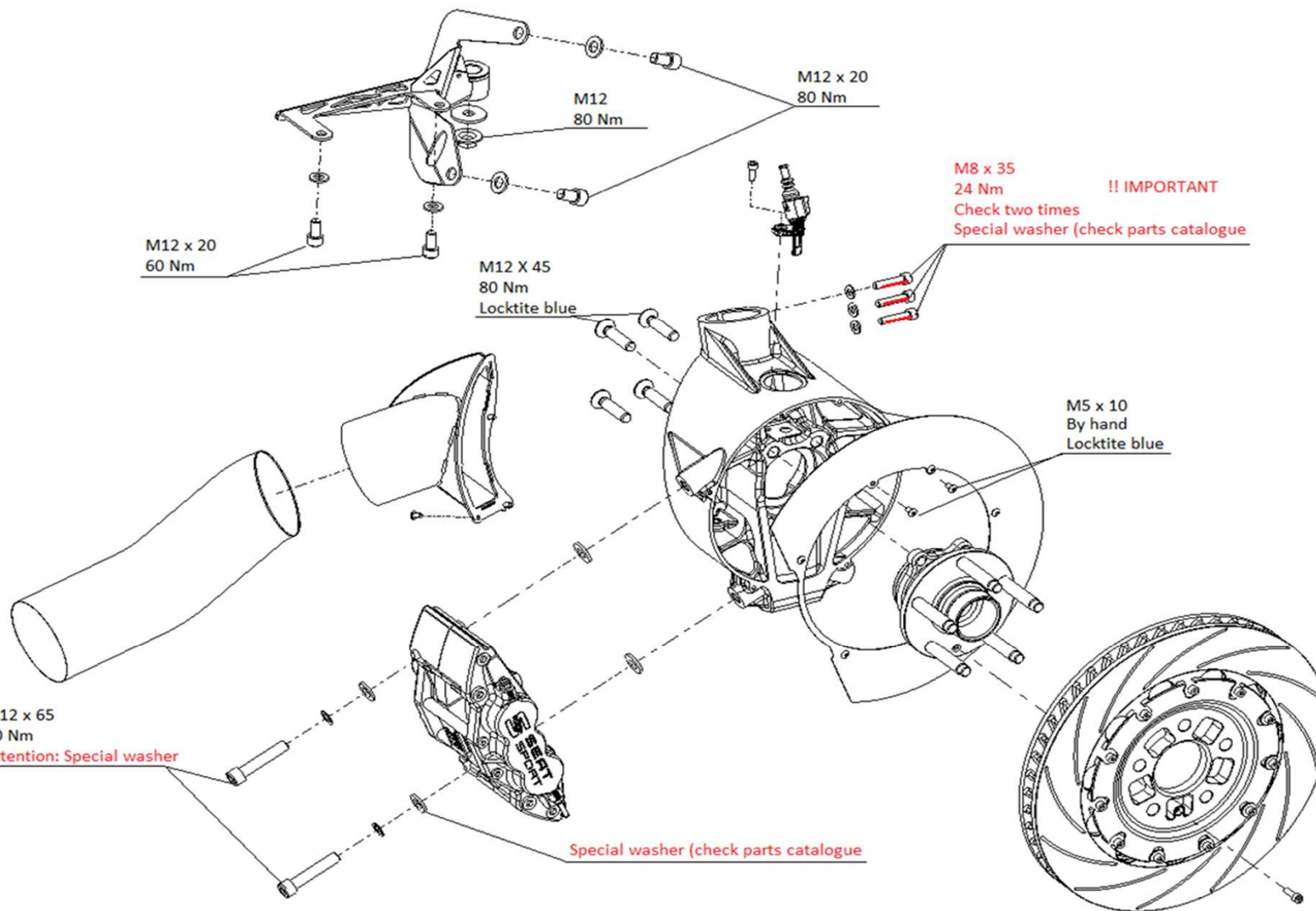
Unterlagen
References

© SEAT SPORT behält sich alle Rechte vor. Das gilt insbesondere fuer Erfindungsrechte, Know-how, Urheberrechte und Namensrechte, sowie fuer das Recht, dieses als gewerbliche Schutzrechte anzumelden. Jede Veruegungsbefugnis ist reserviert.
Están reservados todos los derechos de disposición, en especial a copiar o distribuir.

© All rights remain with SEAT SPORT. This applies especially to rights of invention, know-how, copyrights and rights to name as well as for the right to patent these as commercial protective rights.
All rights of disposition, particularly for copying or distributing, reserved.

Bemerkungen / Notes

Nr. No.	Datum Date	NAME	Genehmigt Appr.	Beschreibung der Aenderung und Aenderungsterminschiessel Revision record and change date code	Typ-Pruef-Dok. und Typ-Pruef-Nr./ Type-appr.-doc and type approval number	CAD-System und Verwaltungssystem - Schluessel CAD-system and administration code	Sicherheits-Dok Safety-doc.
	23/04/14	OSN	ok	Edición		ProE	Konst.Verantw./Design resp.
					Benennung	Front Upright	Name A. Almirall
					Title	Front Axle	Abt./Dept. O.T.
					EA-Nr. / eng. proj. no.	V3FL	Tel.
							Gez./Drawn ProE
							Blatt/sheet 005
							Format/D.size A3

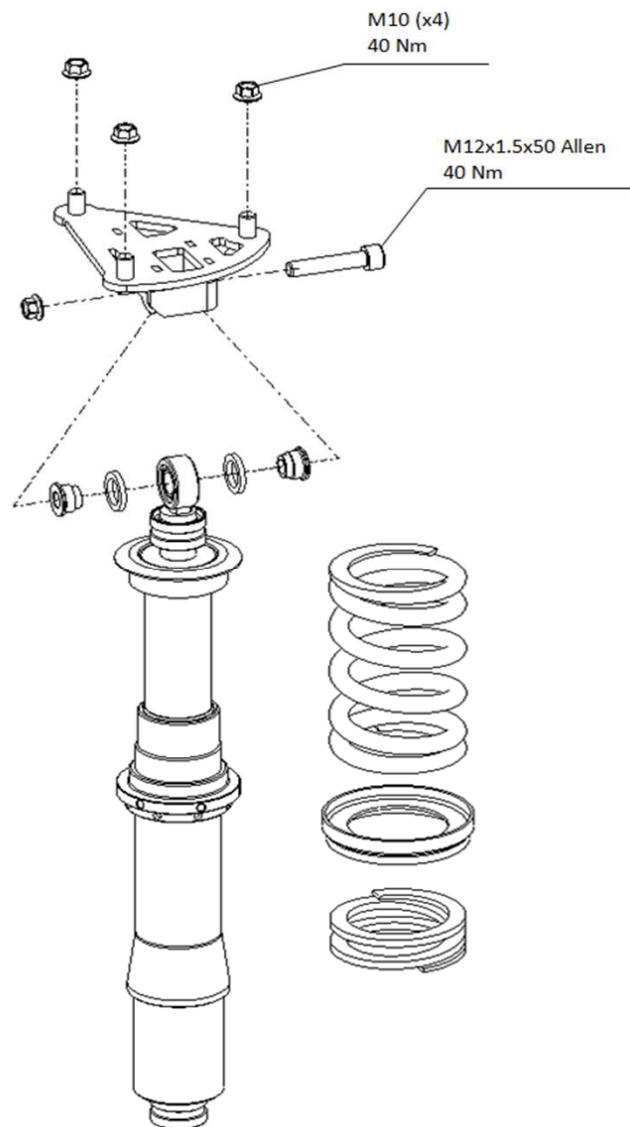
Unterlagen
References

© SEAT SPORT behält sich alle Rechte vor. Das gilt insbesondere fuer Erfindungsrechte, Know-how, Urheberrechte und Namensrechte, sowie fuer das Recht, dieses als gewerbliche Schutzrechte anzumelden. Jede Verfuugungsbefugnis ist. Están reservados todos los derechos de disposición, en especial a copiar o distribuir.

© All rights remain with SEAT SPORT. This applies especially to rights of invention, know-how, copyrights and rights to name as well as for the right to patent these as commercial protective rights. All rights of disposition, particularly for copying or distributing, reserved.

Bemerkungen / Notes

Nr. No.	Datum Date	NAME	Genehmigt Appr.	Beschreibung der Aenderung und Aenderungsterminschiussel Revision record and change date code	Typ-Pruef-Dok. und Typ-Pruef-Nr./ Type-appr.-doc and type approval number	CAD-System und Verwaltungssystem - Schluessel CAD-system and administration code	Sicherheits-Dok Safety-doc.
	23/04/14	OSN	ok	Edición		ProE	Konst.Verantw./Design resp.
					Benennung	Front Shock Absorber	Name A. Almirall
					Title	Front Axle	Abt./Dept. O.T.
					EA-Nr. / eng. proj. no.	V3FL	Tel.
							Gez./Drawn ProE
							Blatt/sheet 006
							Format/D.size A3

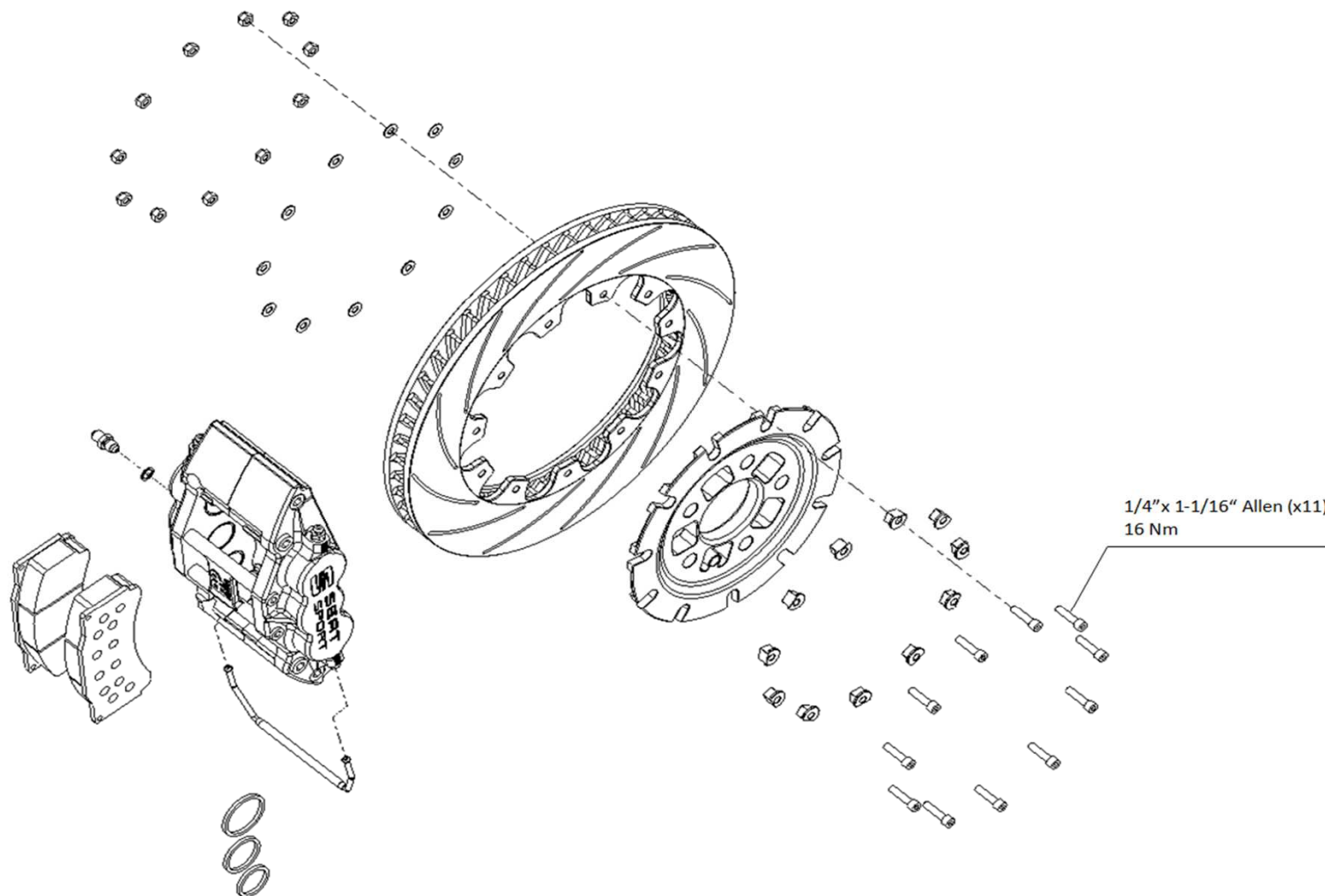
Unterlagen
References

© SEAT SPORT behält sich alle Rechte vor. Das gilt insbesondere fuer Erfindungsrechte, Know-how, Urheberrechte und Namensrechte, sowie fuer das Recht, dieses als gewerbliche Schutzrechte anzumelden. Jede Verfuugungsbefugnis ist. Están reservados todos los derechos de disposición, en especial a copiar o distribuir. © All rights remain with SEAT SPORT. This applies especially to rights of invention, know-how, copyrights and rights to name as well as for the right to patent these as commercial protective rights. All rights of disposition, particularly for copying or distributing, reserved.	Nr. No.	Datum Date	NAME	Genehmigt Appr.	Beschreibung der Aenderung und Aenderungsterminschiussel Revision record and change date code	Typ-Pruef-Dok. und Typ-Pruef-Nr./ Type-appr.-doc and type approval number	CAD-System und Verwaltungssystem - Schluessel CAD-system and administration code	Sicherheits-Dok Safety-doc.
		23/04/14	OSN	ok	Edición	Benennung Front Brake Disc	ProE	Konst.Verantw./Design resp. Name A. Almirall
Bemerkungen / Notes						Title Front Axle		Abt./Dept. O.T.
						EA-Nr. / eng. proj. no.	V3FL	Gez./Drawn Blatt/sheet 007
								Format/D.size A3

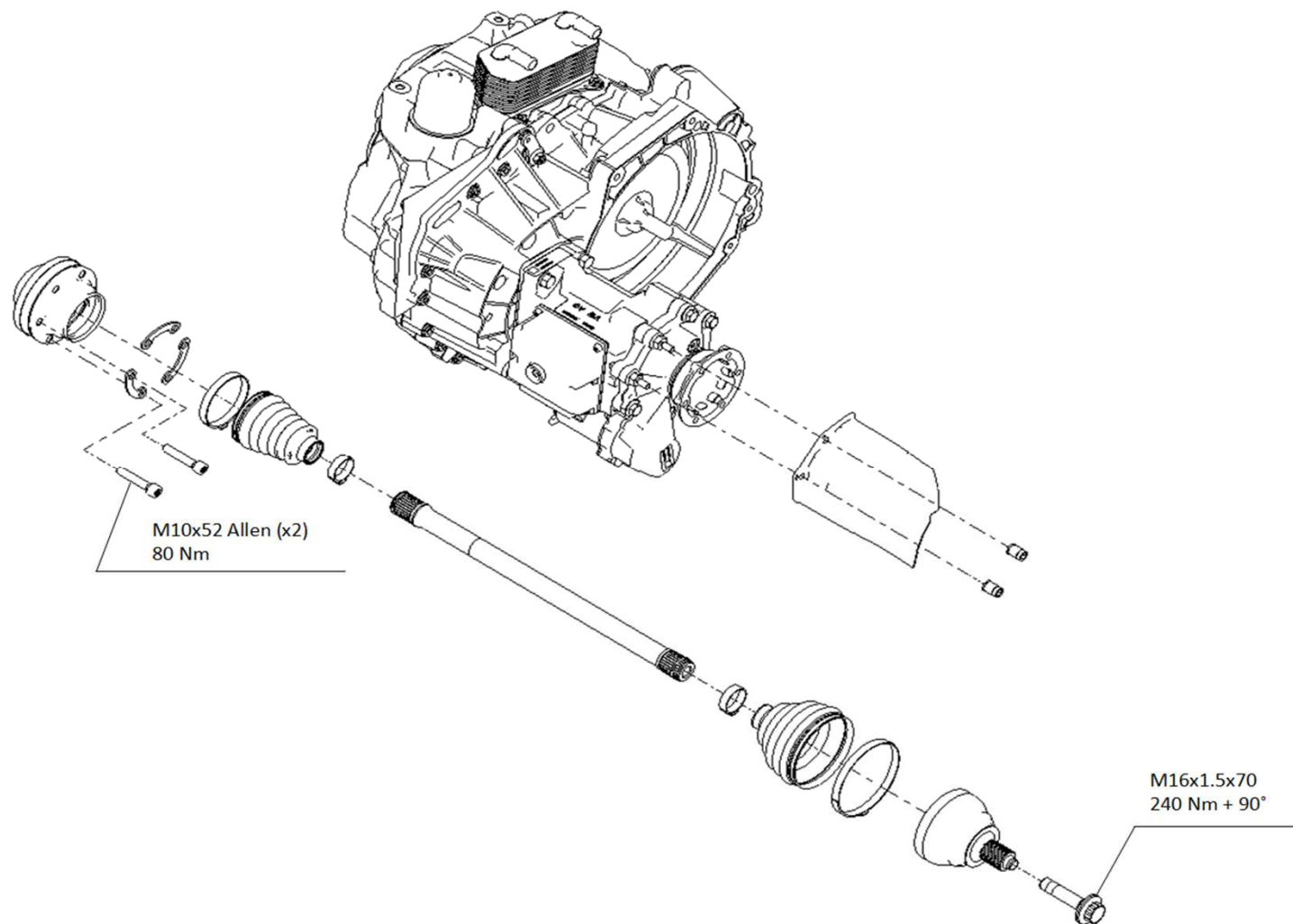
Unterlagen
References

© SEAT SPORT behält sich alle Rechte vor. Das gilt insbesondere fuer Erfindungsrechte, Know-how, Urheberrechte und Namensrechte, sowie fuer das Recht, dieses als gewerbliche Schutzrechte anzumelden. Jede Verfuugungsbefugnis ist. Están reservados todos los derechos de disposición, en especial a copiar o distribuir.

© All rights remain with SEAT SPORT. This applies especially to rights of invention, know-how, copyrights and rights to name as well as for the right to patent these as commercial protective rights. All rights of disposition, particularly for copying or distributing, reserved.

Nr. No.	Datum Date	NAME	Genehmigt Appr.	Beschreibung der Aenderung und Aenderungsterminschiussel Revision record and change date code	Typ-Pruef-Dok. und Typ-Pruef-Nr./ Type-appr.-doc and type approval number	CAD-System und Verwaltungssystem - Schluessel CAD-system and administration code	Sicherheits-Dok Safety-doc.
	23/04/14	OSN	ok	Edición		ProE	Konst.Verantw./Design resp.
Benennung					Drive Shaft		Name A. Almirall
					Title		Front Axle
Bemerkungen / Notes					EA-Nr. / eng. proj. no.		Tel.
					V3FL		Gez./Drawn ProE
					Blatt/sheet 008		Format/D.size A3

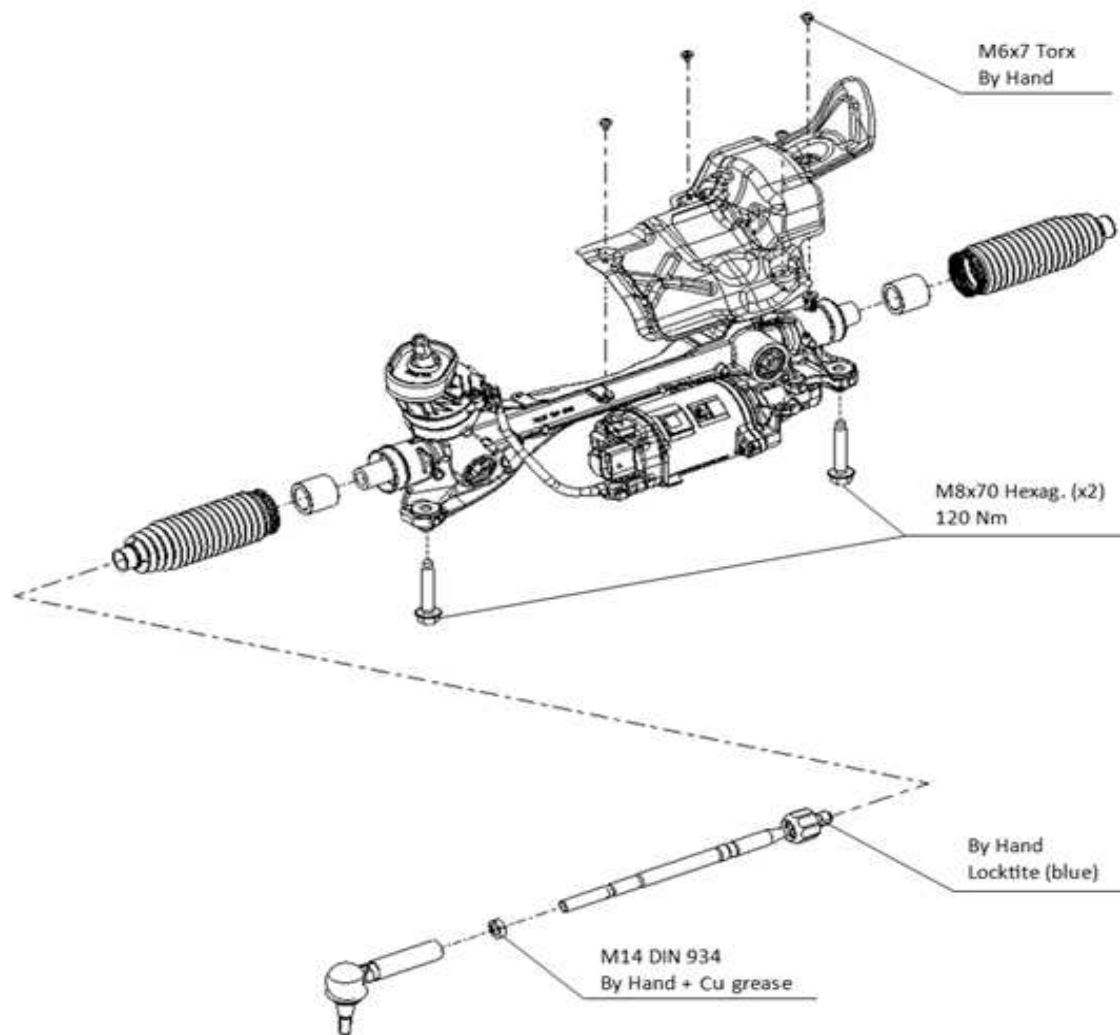
Unterlagen
References

© SEAT SPORT behält sich alle Rechte vor. Das gilt insbesondere fuer Erfindungsrechte, Know-how, Urheberrechte und Namensrechte, sowie fuer das Recht, dieses als gewerbliche Schutzrechte anzumelden. Jede Verfuegungsbefugnis ist. Están reservados todos los derechos de disposición, en especial a copiar o distribuir. © All rights remain with SEAT SPORT. This applies especially to rights of invention, know-how, copyrights and rights to name as well as for the right to patent these as commercial protective rights. All rights of disposition, particularly for copying or distributing, reserved.	Nr. No.	Datum Date	NAME	Genehmigt Appr.	Beschreibung der Aenderung und Aenderungsterminschiussel Revision record and change date code	Typ-Pruef-Dok. und Typ-Pruef-Nr./ Type-appr.-doc and type approval number	CAD-System und Verwaltungssystem - Schluessel CAD-system and administration code	Sicherheits-Dok Safety-doc.
		23/04/14	OSN	ok	Edición	Benennung Steering Rack	ProE	Konst.Verantw./Design resp. Name A. Almirall
Bemerkungen / Notes						Title Front Axle		Abt./Dept. O.T.
						EA-Nr. / eng. proj. no.	V3FL	Tel. Gez./Drawn ProE Blatt/sheet 009 Format/D.size A3

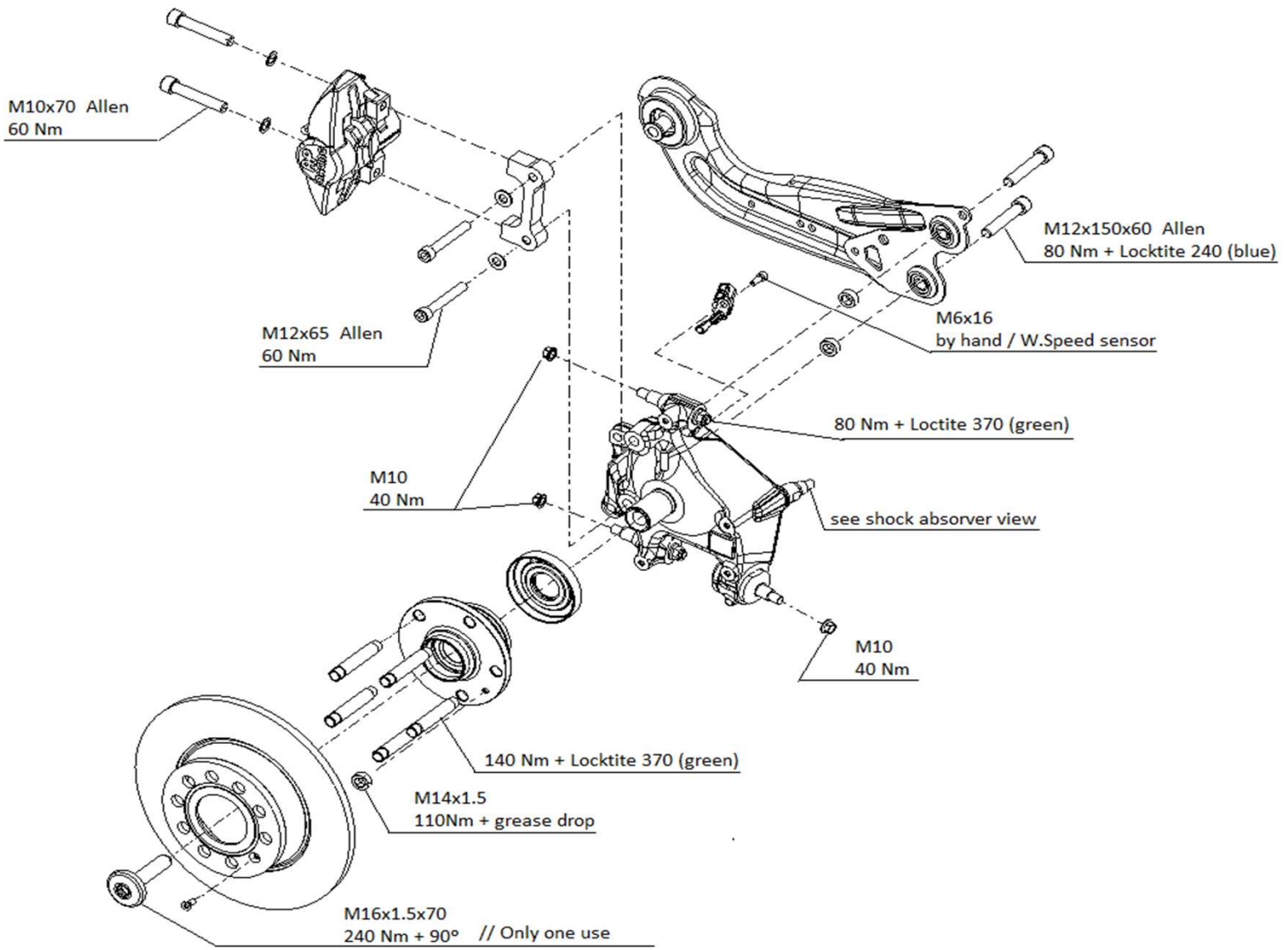
Unterlagen
References

© SEAT SPORT behält sich alle Rechte vor. Das gilt insbesondere fuer Erfindungsrechte, Know-how, Urheberrechte und Namensrechte, sowie fuer das Recht, dieses als gewerbliche Schutzrechte anzumelden. Jede Verfuugungsbefugnis ist. Están reservados todos los derechos de disposición, en especial a copiar o distribuir.
 © All rights remain with SEAT SPORT. This applies especially to rights of invention, know-how, copyrights and rights to name as well as for the right to patent these as commercial protective rights. All rights of disposition, particularly for copying or distributing, reserved.

Nr. No.	Datum Date	NAME	Genehmigt Appr.	Beschreibung der Aenderung und Aenderungsterminschiussel Revision record and change date code
	23/04/14	OSN	ok	Edición

Typ-Pruef-Dok. und Typ-Pruef-Nr. / Type-appr. - doc and type approval number	CAD-System und Verwaltungssystem - Schluessel CAD-system and administration code	Sicherheits-Dok Safety-doc.
ProE		Konst.Verantw./Design resp.
Benennung Rear Wheel Hub Assy.		Name A. Almirall
Title Rear Axle		Abt./Dept. O.T.
EA-Nr. / eng. proj. no.		Tel.
V3FL		Gez./Drawn ProE
		Blatt/sheet 010
		Format/D.size A3

Unterlagen
References

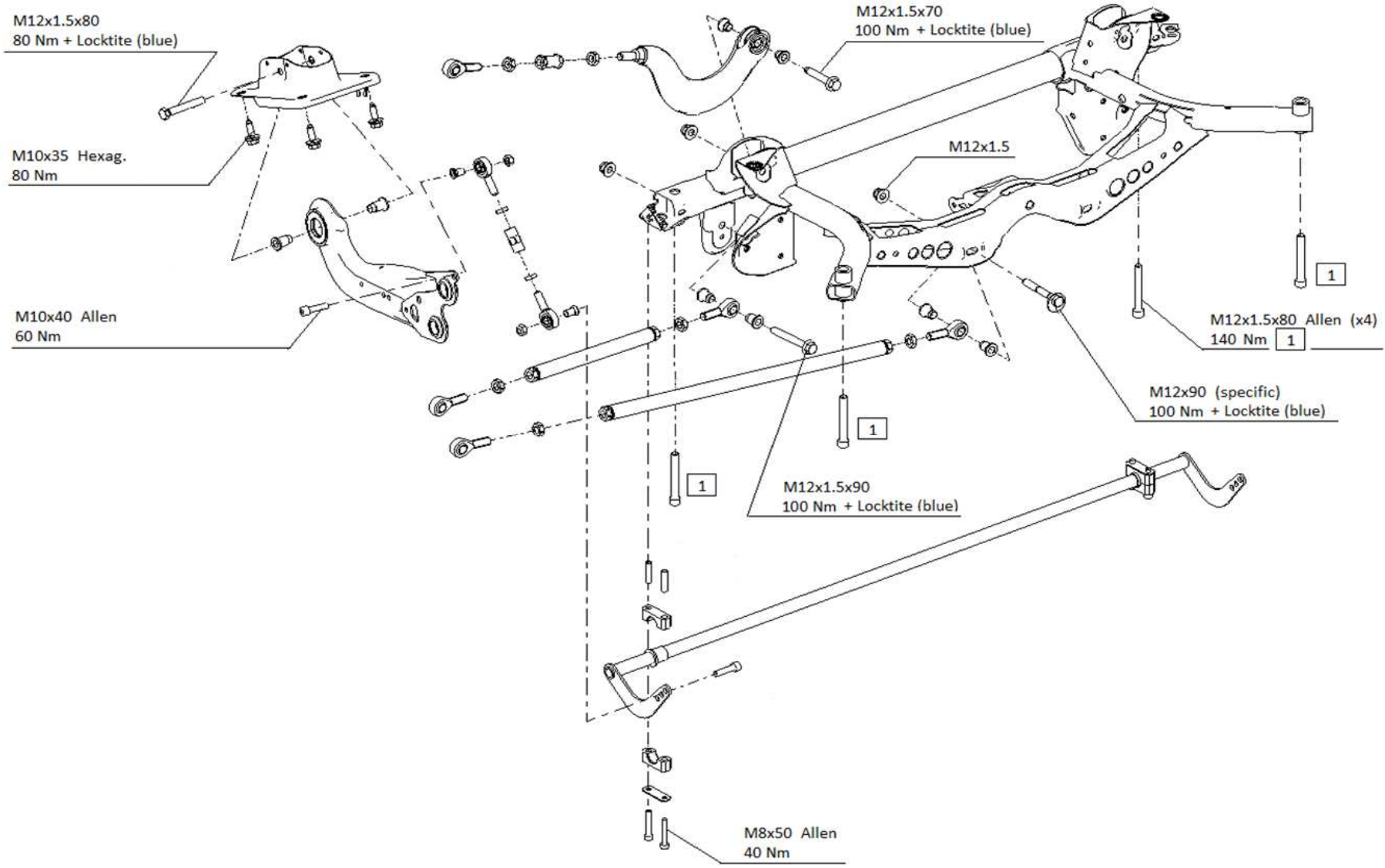

© SEAT SPORT behält sich alle Rechte vor. Das gilt insbesondere fuer Erfindungsrechte, Know-how, Urheberrechte und Namensrechte, sowie fuer das Recht, dieses als gewerbliche Schutzrechte anzumelden. Jede Verfuugungsbefugnis ist, dieses als gewerbliche Schutzrechte anzumelden. Jede Verfuugungsbefugnis ist, dieses als gewerbliche Schutzrechte anzumelden. Jede Verfuugungsbefugnis ist, dieses als gewerbliche Schutzrechte anzumelden.

Están reservados todos los derechos de disposición, en especial a copiar o distribuir.

© All rights remain with SEAT SPORT. This applies especially to rights of invention, know-how, copyrights and rights to name as well as for the right to patent these as commercial protective rights.

All rights of disposition, particularly for copying or distributing, reserved.

Nr. No.	Datum Date	NAME	Genehmigt Appr.	Beschreibung der Aenderung und Aenderungsterminschiussel Revision record and change date code
	23/04/14	OSN	ok	Edición

Typ-Pruef-Dok. und Typ-Pruef-Nr. / Type-appr. - doc and type approval number	CAD-System und Verwaltungssystem - Schluessel CAD-system and administration code	Sicherheits-Dok Safety-doc.
ProE		Konst.Verantw./Design resp.
Benennung Rear Axle Assembly		Name A. Almirall
Title Rear Axle		Abt./Dept. O.T.
EA-Nr. / eng. proj. no.		Tel.
V3FL		Gez./Drawn ProE
		Blatt/sheet 011
		Format/D.size A3

Bemerkungen / Notes

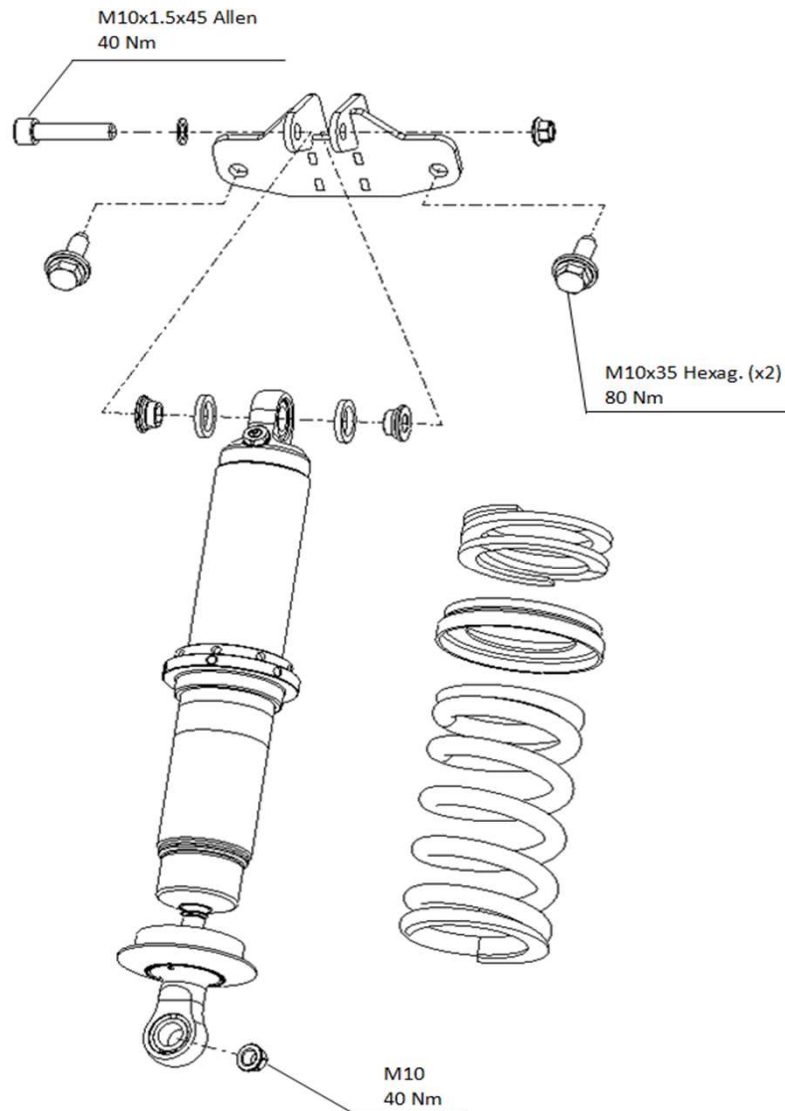
Unterlagen
References

© SEAT SPORT behält sich alle Rechte vor. Das gilt insbesondere fuer Erfindungsrechte, Know-how, Urheberrechte und Namensrechte, sowie fuer das Recht, dieses als gewerbliche Schutzrechte anzumelden. Jede Verfuugungsbefugnis ist. Están reservados todos los derechos de disposición, en especial a copiar o distribuir.
 © All rights remain with SEAT SPORT. This applies especially to rights of invention, know-how, copyrights and rights to name as well as for the right to patent these as commercial protective rights. All rights of disposition, particularly for copying or distributing, reserved.

Nr. No.	Datum Date	NAME	Genehmigt Appr.	Beschreibung der Aenderung und Aenderungsterminschiussel Revision record and change date code	Typ-Pruef-Dok. und Typ-Pruef-Nr./ Type-appr.- doc and type approval number	CAD-System und Verwaltungssystem - Schluessel CAD-system and administration code	Sicherheits-Dok Safety-doc.
	23/04/14	OSN	ok	Edición		ProE	Konst.Verantw./Design resp.
Bemerkungen / Notes					Benennung Rear Shock Absorber		Name A. Almirall
					Title Rear Axle		Abt./Dept. O.T.
					EA-Nr. / eng. proj. no.		Gez./Drawn ProE
					V3FL		Blatt/sheet 012
							Format/D.size A3



SEAT SPORT

Modelo / Model

León Supercopa Mk2

Technical Form N°

Año / Year 2008

Extension N°

01/09 ET

EXTENSIÓN DE FICAH TÉCNICA
TECHNICAL FORM EXTENSION

- ES** Evolution sportive du type / Sporting evolution of the type **VO** Variante option / Option variant
- ET** Evolution normale du type / Normal evolution of the type **VP** Variante de Production / Production variant
- VF** Variante de fourniture / Supply variant **ER** Erratum / Erratum

Véhicule : Constructeur
Vehicle : Manufacturer

SEAT SPORT

Modèle et type
Model and type

LEON SUPERCOPA MK2 2008

Homologation valable à partir du
Homologation valid as from

21 MAY 2008

Page or ext.	Article	Description
26/40	10.4	<p>The use of this complete ET is compulsory from the date of publication</p> <p>STEERING WHEEL RADIATOR</p> <p>Photo 1 Radiator</p> <p>Largo cuerpo / overal body width A= 358</p> <p>Nº de pasos / nº of rows B= 10</p> <p>Photo 2 Radiator installed in the car frontend. In fornt of the engine intercooler</p> <p>Referance : Catalogo de piezas LEON SUPERCOPA</p> <p>LEON SUPERCOPA Spare parts catalog</p> <p>Page 38 Photo P.A.S. Part nº V4PL422885</p>

Marque
Make **SEAT SPORT**

Modèle
Model **LEON SUPERCOPA MK2**

Technical Form N°
Año / Year 2008
Extension N°

01/09 ET

Page or ext.	Article	Description
26/40	10.5	<p>The use of this complete ET is compulsory from the date of publication</p> <p>STEERING BELL PULLEY</p> <p>Photo 3 Steering bell pulley</p> <p>Photo 4 Diametro exterior de la polea / External diameter d= 131 mm</p> <p>Reference : Catalogo Leon supercopa / Leon Supercopa catalog</p> <p>Page 82 Photo 7 Part n° V4PL 711255</p>

Marque
Make **SEAT SPORT**

Modèle
Model **LEON SUPERCOPA MK2**

Año / Year 2008

Extension N°

01/09 ET

PHOTO N° 1

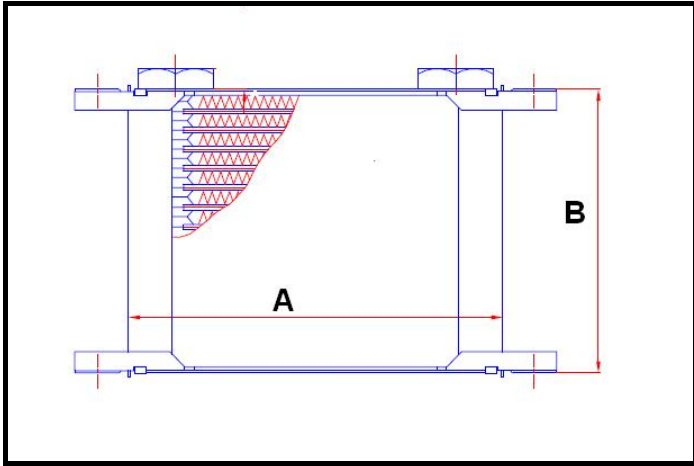

PHOTO N° 2



PHOTO N° 3



PHOTO N° 4

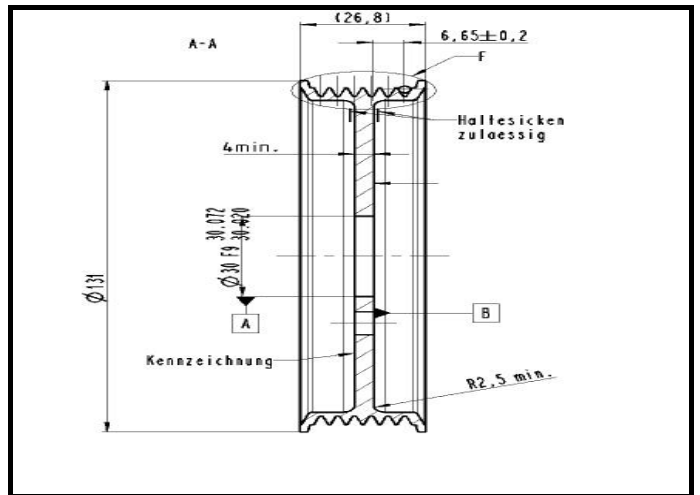

MONTAJE RADIADOR SERVODIRECCIÓN 2009

Referencias

Descripción	Referencia	Cantidad
Polea para correa	V4PL145255	1
Radiador servo-dirección	V4PL422885	1
Siletnblock doble espiga	V4PT133637	4
Tuerca M6 Din 985	VN0003090430	8
Tubo entrada radiador servo	V4PL422899C	1
Tubo salida radiador servo	V4PL422892C	1

Desmontaje y Montaje:

Las piezas arriba descritas se montan en el SEAT León Supercopa Mk2 sin apenas modificaciones. Sigam los pasos que a continuación les describimos.

1. Desmontar el parachoques, splitter y vaciar de aceite hidráulico el circuito del radiador.
2. Desmontar el radiador de aceite de serpentín actual, los soportes del radiador y el tubo de entrada y el de salida del radiador. No es necesario desmontar el frontend ni el intercooler para este retrabajo, pero si se desea hacerlo de forma mas cómoda, desmonte el frontend del coche.

Piezas a desmontar: (ver foto 1, piezas 23 a 27 catalogo 2008 Pág. 62)

Foto 1:

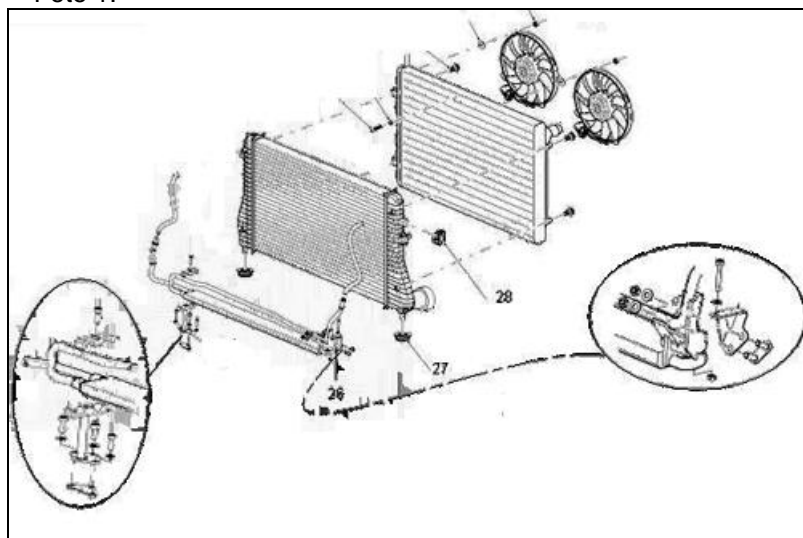

3. Utilizar el agujero central en el frontend del soporte derecho del radiador desmontado (foto 2 punto B) como punto de partida para situar y marcar los puntos de anclaje del nuevo radiador. Es conveniente tapar con cinta adhesiva los agujeros (foto 2 punto A) que no se van a utilizar.



Foto 2

4. Situar el nuevo radiador utilizando el punto B de la foto 2 y marcar los otros 3 puntos de anclaje en el plástico del frontend. Retirar el radiador y realizar los tres agujeros restantes con una broca de 6mm. (fotos 3 y 4)

foto 3



foto 4

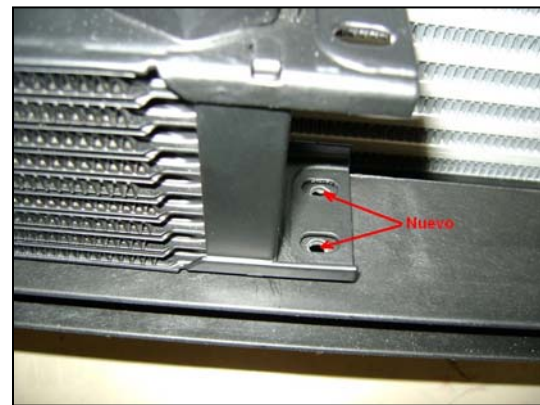

5. Colocar los y fijar los 4 silentblocks de espiga en los agujeros realizados. (foto 5)

Foto 5



6. Colocar y fijar el radiador nuevo de servo-dirección (foto 6). A continuación ya se puede colocar y fijar los tubos de entrada y salida del radiador, colocándolos en la misma posición que tenían en el frontend anterior. (foto 7)

Foto 6



Foto 7

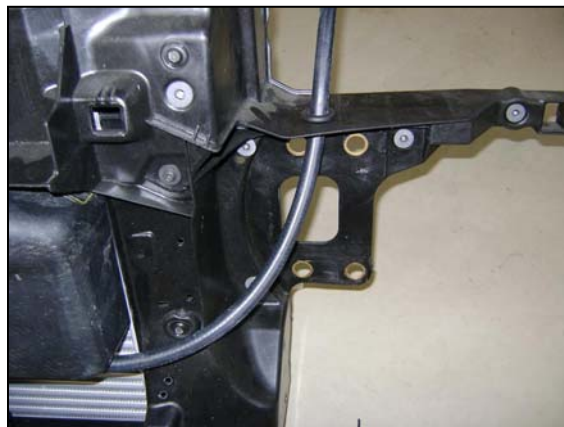

7. Desmontar y montar la nueva polea de la bomba de servo-dirección siguiendo los pasos habituales. El apriete de los tornillos de la polea se realiza a mano añadiendo fijador de tornillos del tipo medio (Loctite 242).
Nota: Se recomienda hacer una revisión ocular a la correa y sustituir en caso de pequeñas piedras adheridas en el interior del poli V o grietas externas.
8. Añadir aceite hidráulico hasta el nivel máximo del indicador de la botella de expansión. Poner el motor en marcha durante cinco segundos y volver a pararlo (durante esta operación no debe girarse el volante). Rehacer nivel y repetir el arranque y paro en 5 segundos. Rehacer nivel y ya se puede poner en marcha definitivamente controlando que el nivel de aceite quede entre el mínimo y máximo de la varilla de control cuando el agua motor se encuentre a 85° C.
9. Montar el Splitter.
10. Retrabajar el parachoques haciendo una entrada en el lado izquierdo igual a la ya hecha en el lado derecho, (foto 8), y montarlo.
 - a. Entre centros de entradas 382mm
 - b. Fondo 45mm
 - c. Ancho 25mm

Foto 8



Notas:

- Recordamos consultar el Manual del Usuario para controlar el kilometraje recomendado de vida útil de la bomba y correa de servo-dirección. En caso de haberse sobrepasado se debe sustituir.
- Es recomendable desmontar el radiador de agua e intercooler para la limpieza de los mismos.
- Se recomienda utilizar el líquido hidráulico descrito en el Catálogo de piezas.



SEAT SPORT

Modelo / Model

León Supercopa Mk2

Technical Form N°

Año / Year 2008

Extension N°

01/09 VO

**EXTENSIÓN DE FICAH TÉCNICA
TECHNICAL FORM EXTENSION**

- ES** Evolution sportive du type / Sporting evolution of the type
- VO** Variante option / Option variant
- ET** Evolution normale du type / Normal evolution of the type
- VP** Variante de Production / Production variant
- VF** Variante de fourniture / Supply variant
- ER** Erratum / Erratum

Véhicule : Constructeur
Vehicle : Manufacturer

SEAT SPORT

Modèle et type
Model and type

LEON SUPERCOPA MK2 2008

Homologation valable à partir du
Homologation valid as from

21 MAY 2008

Marque
Make **SEAT SPORT**

Modèle
Model **LEON SUPERCOPA MK2**

Technical Form N°

Año / Year 2008

Extension N°

01/09 VO

Page or ext.	Article	Description		
29/40	11.3	<p>MUELLES / SPRING</p> <p>Photo 1 : Montaje muelle de suspension / Suspension spring assembling:</p> <table style="width: 100%; border: none;"> <tr> <td style="width: 50%; vertical-align: top;"> <p>a) Delanteros / Front</p> <p>250-60-70 -- --</p> </td> <td style="width: 50%; vertical-align: top;"> <p>b) Delanteros y traseros / Frotn & Rear</p> <p>160-60-50 + 60-60-2</p> <p>160-60-60 + 60-60-2</p> <p>160-60-70 + 60-60-2</p> <p>160-60-80 + 60-60-2</p> <p>160-60-90 + 60-60-2</p> <p>160-60-100 + 60-60-2 (new)</p> <p>160-60-110 + 60-60-2</p> <p>160-60-130 + 60-60-2</p> </td> </tr> </table>	<p>a) Delanteros / Front</p> <p>250-60-70 -- --</p>	<p>b) Delanteros y traseros / Frotn & Rear</p> <p>160-60-50 + 60-60-2</p> <p>160-60-60 + 60-60-2</p> <p>160-60-70 + 60-60-2</p> <p>160-60-80 + 60-60-2</p> <p>160-60-90 + 60-60-2</p> <p>160-60-100 + 60-60-2 (new)</p> <p>160-60-110 + 60-60-2</p> <p>160-60-130 + 60-60-2</p>
<p>a) Delanteros / Front</p> <p>250-60-70 -- --</p>	<p>b) Delanteros y traseros / Frotn & Rear</p> <p>160-60-50 + 60-60-2</p> <p>160-60-60 + 60-60-2</p> <p>160-60-70 + 60-60-2</p> <p>160-60-80 + 60-60-2</p> <p>160-60-90 + 60-60-2</p> <p>160-60-100 + 60-60-2 (new)</p> <p>160-60-110 + 60-60-2</p> <p>160-60-130 + 60-60-2</p>			

Marque
Make **SEAT SPORT**

Modèle
Model **LEON SUPERCOPA MK2**

Año / Year 2008

Extension N°

01/09 VO

Page or ext.	Article	Description
30/40	11.6.1	<p>The use of this complete VO is a option from the date of publication</p> <p>Reference : Catalogo Leon Supercopa 2009</p> <p>Leon Supercopa 2009 Spare parts catalog Page 33 & Page 49</p> <p>BARRA ESTABILIZADORA POSTERIOR / REAR ANTI ROLL BAR</p> <p>Photo 2 Rear Anti roll bar</p> <p>Longitud total A es la siguiente: Long A according with the following sketch: <u>A = 1069 ± 1.5 mm</u></p> <p>Dimensión del tubo de torsión Torsion bar dimension: <u>B = 688 ± 1 mm</u> <u>D = Ø 22 x 5</u></p> <p>Dimensiones Espada: Blade dimension: Tube centreline to adjustment 1 C = 130 ± 1 mm. Adjustment 1 to adjustment 2 E = 16 ± 0.5 mm. Adjustment 1 to adjustment 3 F = 33 ± 0.5 mm.</p> <p>Reference : Catalogo Leon supercopa / Leon Supercopa catalog Page 35 Part nº V4PL505407B</p>

Marque
Make **SEAT SPORT**

Modèle
Model **LEON SUPERCOPA MK2**

Technical Form N°
Año / Year 2008
Extension N°

01/09 VO

PHOTO N° 1

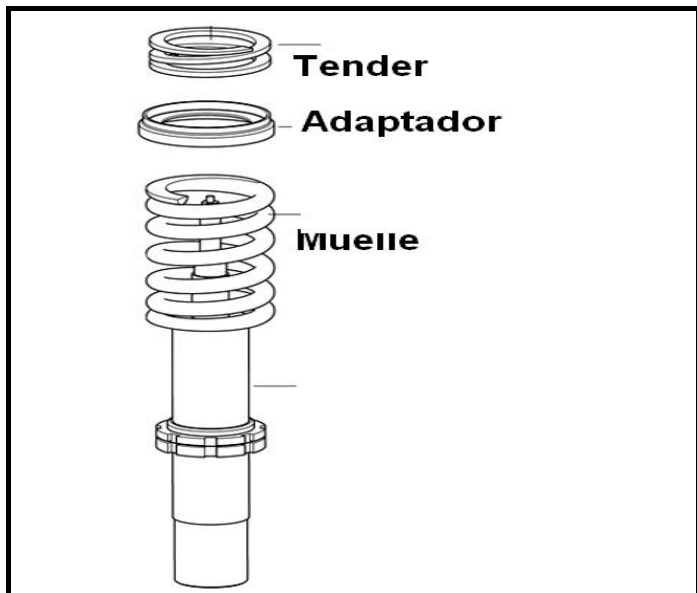
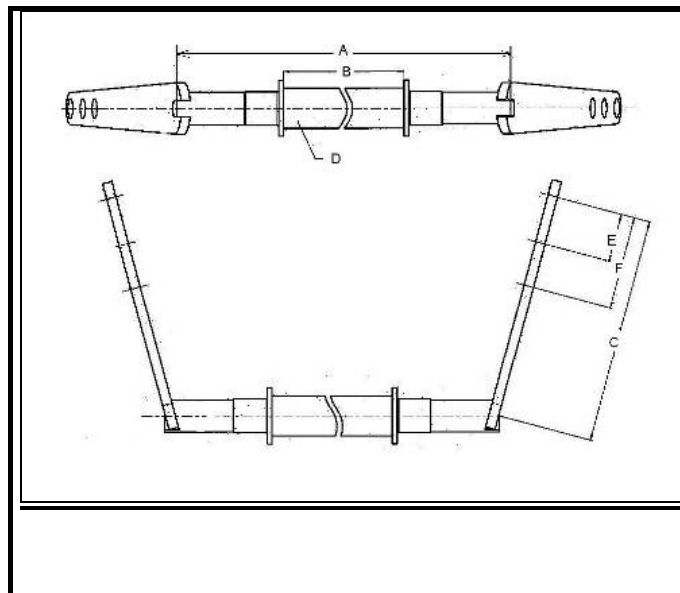

PHOTO N° 2





Nota técnica Informativa ***Technical Information Note***

Modificaciones León Supercopa MK2

A continuación se describen las actualizaciones realizadas sobre el León Supercopa MK2 2008 para la temporada 2009. En dos grupos, se detallan las piezas de uso obligatorio y las opcionales.

De uso obligatorio para participar en la Eurocup SEAT León:

Descripción	Referencia	Cantidad
Polea para correa	V4PL145255	1
Radiador servo-dirección*	V4PL422885	1
Pastillas de freno anterior Ferodo***	V4PL615115B	1
Pastilla de freno posterior Ferodo***	V4PL615415A	1

De uso opcional como set up del coche:

Descripción	Referencia	Cantidad
Barra estabilizadora 20% mas dura**	V4PL511407B	1
Muelle de 100 Nm**	VN0020065600	2

* Ver pdf instrucciones de montaje de SEAT Sport.

** Aprobado en la Ficha Técnica Leon Supercopa MK2 en VO.

*** Disponibles en el Catalogo Supercopa MK2 2009 "SOLO EUROCUP".



Nota técnica Informativa ***Technical Information Note***

Technical improvements from León Supercopa MK2

Following are detailed the improvements done on the SEAT León Supercopa MK2 2008 for the season 2009. In two groups are detailed the compulsory parts and the optional ones.

Compulsory use from Eurocup SEAT León:

Descripción	Referencia	Cantidad
Steering Wheel puley	V4PL145255	1
Radiator from steering Wheel*	V4PL422885	1
Front brake pads Ferodo***	V4PL615115B	1
Rear brake pads Ferodo***	V4PL615415A	1

Optional for car set up:

Descripción	Referencia	Cantidad
Anti roll bar 20 harder**	V4PL511407B	1
Spring 100 Nm**	VN0020065600	2

* Se mounting instructions pdf from SEAT Sport.

** Technical Form from Leon Supercopa MK2 approved in VO.

*** Available on the Parts Catalogue León Supercopa MK2 2009 "EUROCUP ONLY".